

20-JUL-2020

RD258.dgn

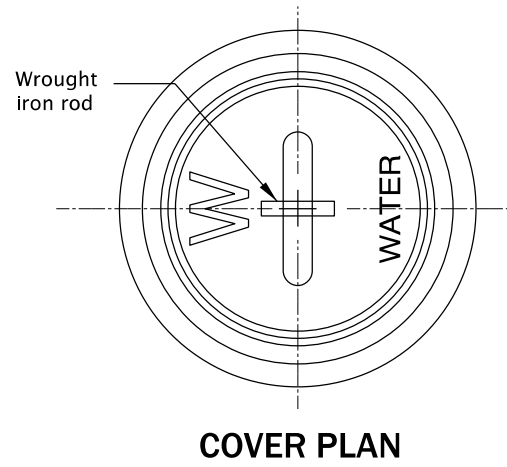

COVER PLAN

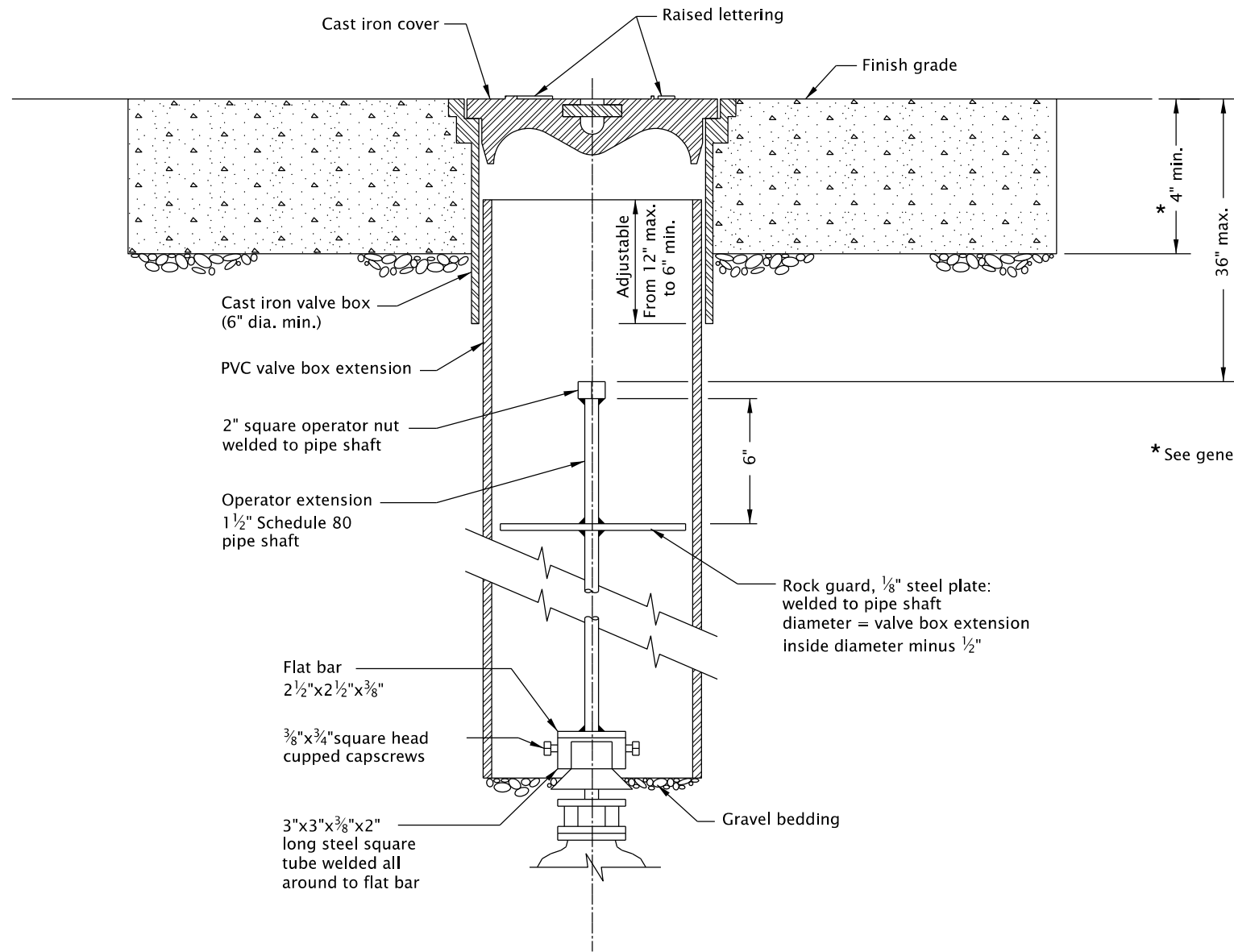

VALVE BOX EXTENSION SECTION

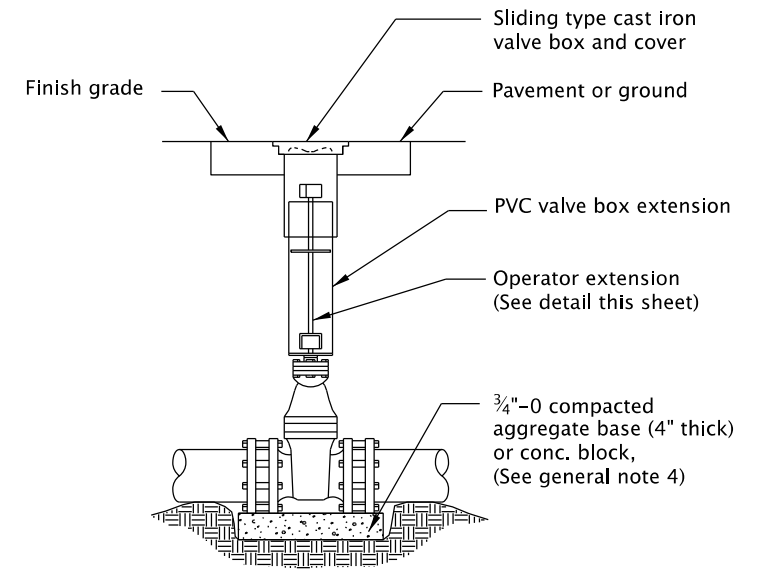

VALVE BOX ASSEMBLY DETAIL

GENERAL NOTES FOR ALL DETAILS ON THIS SHEET:

1. Valve box not to rest on operating assembly.
2. Operator extension required when valve nut is deeper than 4' from finish grade.
3. Center valve box on axis of operator nut.
4. Valves 12" and smaller shall be provided with compacted aggr. base on undisturbed ground. Valves greater than 12" shall be installed on precast concrete block, (4" thick).
5. Welds shall be minimum 1/4" all around.
6. Hot dip galvanize operator extension after fabrication.
7. Casting shall meet H20 load requirement.
8. Provide concrete or asphalt pad (24" square, 4" thick), when required.
9. See project plans for details not shown.

The selection and use of this Standard Drawing, while designed in accordance with generally accepted engineering principles and practices, is the sole responsibility of the user and should not be used without first consulting a Registered Professional Engineer.

All materials shall be in accordance with the current Oregon Standard Specifications.

OREGON STANDARD DRAWINGS
VALVE BOX AND OPERATOR EXTENSION ASSEMBLY

2024

DATE	REVISION	DESCRIPTION

CALC. BOOK NO. --- N/A --- SDR DATE- 25-JUL-2017 --- **RD258**

Effective Date: December 1, 2023 – May 31, 2024

TABLE A

"A" (in)	"B" (in)	"C" (in)	"D" (in)
4	10	4	8
6	10	4	8
8	10	6	10
10	10	6	10
12	12	6	10
15	12	6	10
18	16	6	12
21	16	6	12
24	18	6	12
30	18	6	12
36	24	6	14
42	24	6	14
48	24	6	14
54	24	6	14
60	24	6	14
66	24	6	14
72	24	6	14

For pipes over 72" diameter, see general note 3.

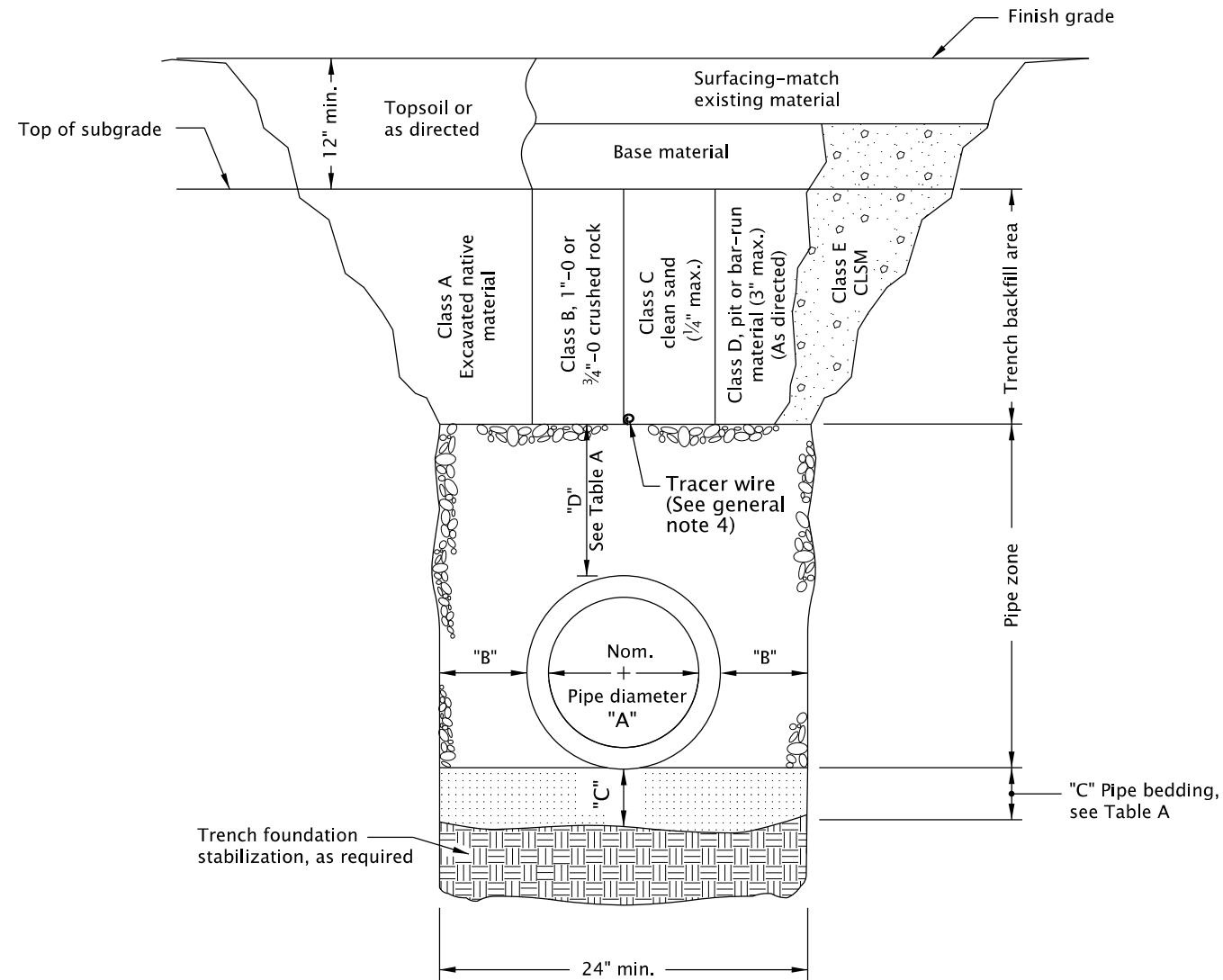

MULTIPLE INSTALLATIONS	
DIAMETER	MIN. SPACE BETWEEN PIPES
Up to 48"	24"
48" to 72"	One half (1/2) dia. of pipe

GENERAL NOTES FOR ALL DETAILS ON THIS SHEET:

1. Surfacing of paved areas shall comply with street cut Std. Dwg. RD302.
2. For pipe installation in embankment areas where the trench method will not be used and the pipe is ≥ 36 " diameter, increase dimension "B" to nominal pipe diameter.
3. Pipes over 72" diameter are structures, and are not applicable to this drawing.
4. See Std. Dwg. RD336 for tracer wire details (When required).

The selection and use of this Standard Drawing, while designed in accordance with generally accepted engineering principles and practices, is the sole responsibility of the user and should not be used without first consulting a Registered Professional Engineer.

All materials shall be in accordance with the current Oregon Standard Specifications.			
OREGON STANDARD DRAWINGS			
TRENCH BACKFILL, BEDDING, PIPE ZONE AND MULTIPLE INSTALLATIONS			
2024			
DATE	REVISION DESCRIPTION		
CALC. BOOK NO.	N/A	SDR DATE	RD300

20-JAN-2023

RD339.dgn

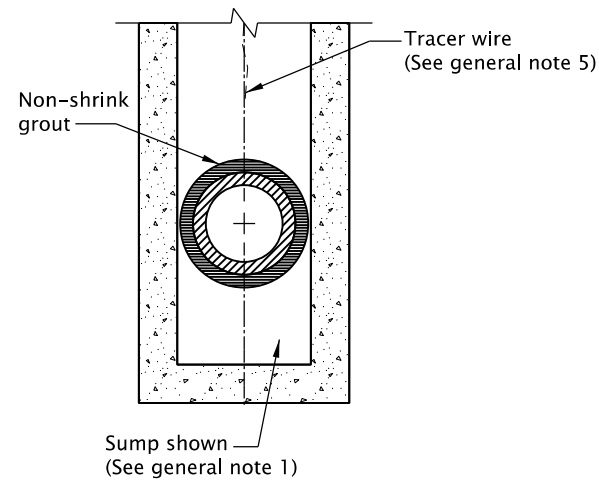

SECTION B-B

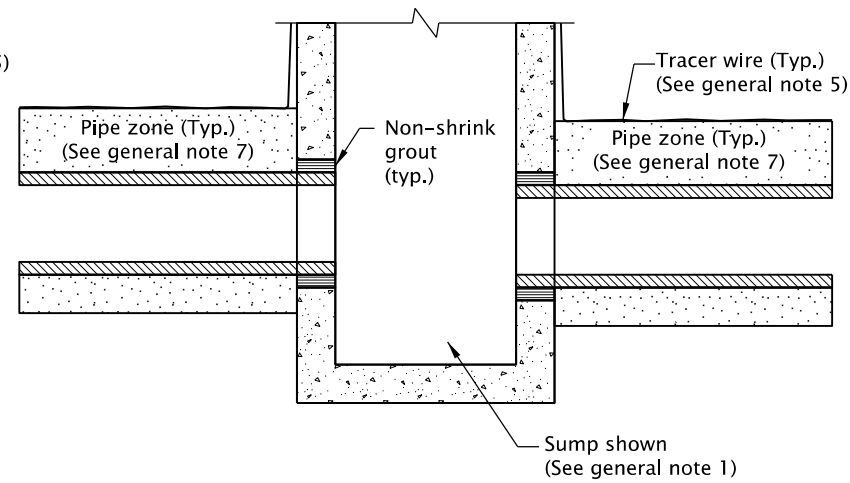

SECTION A-A

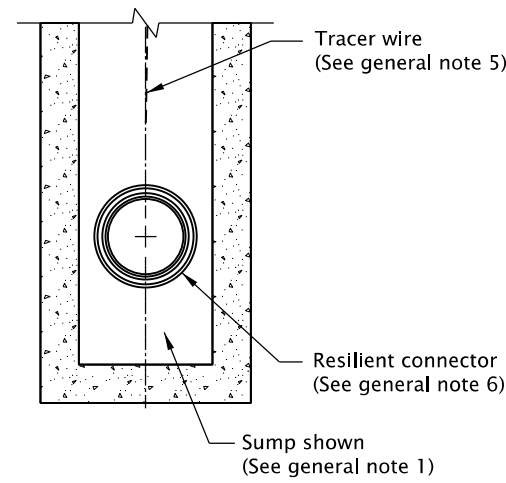

SECTION D-D

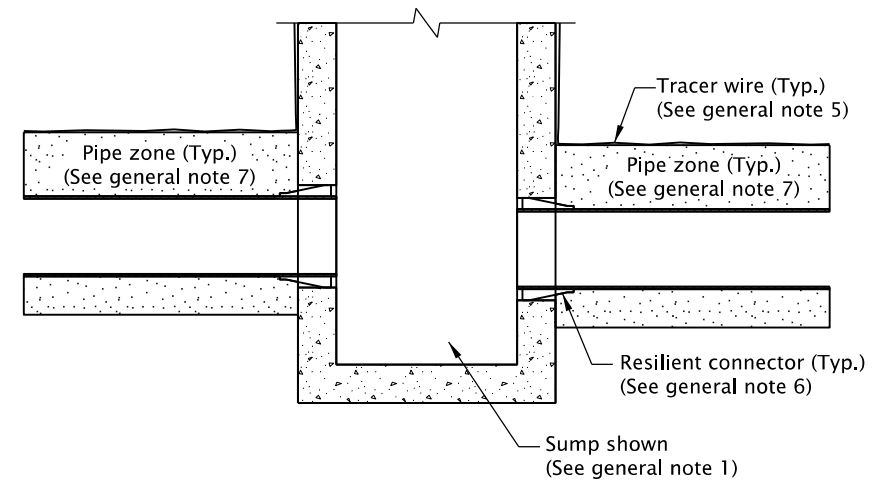

SECTION C-C

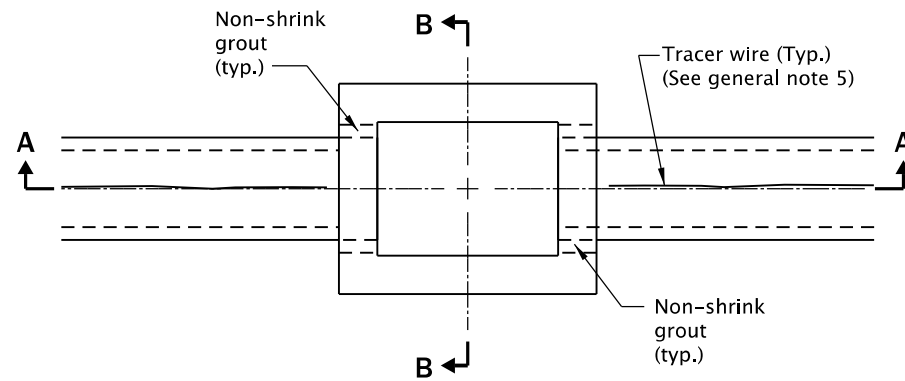

PLAN

CONNECTION OF RIGID PIPE TO STRUCTURE

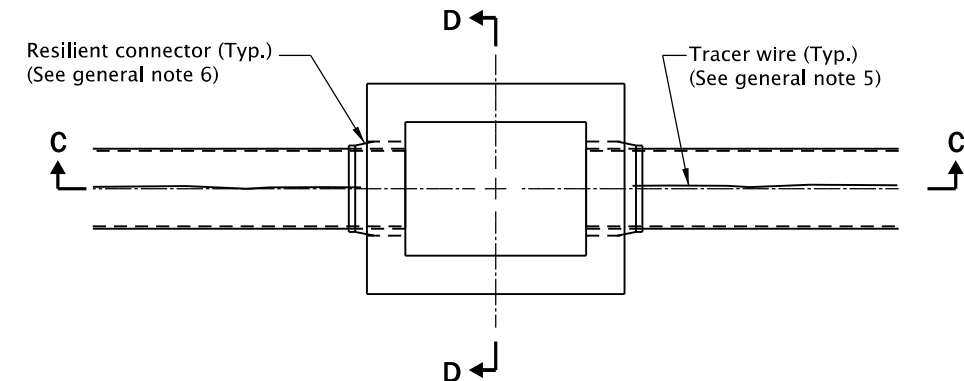

PLAN

CONNECTION OF FLEXIBLE PIPE TO STRUCTURE

GENERAL NOTES FOR ALL DETAILS ON THIS SHEET:

1. See Std. Dwgs. RD364, RD365, and RD366 for inlet details not shown.
2. See appropriate standard drawings or special project details for other similar structures.
3. Location, elevation, diameter, slope, and number of pipe(s) varies, see project plans.
4. Maximum pipe diameter varies with pipe material.
5. All connecting pipes shall have a tracer wire, or approved alternate. See Std. Dwg. RD336 for tracer wire details.
6. When flexible pipe is used, install resilient connectors conforming to requirements of ASTM C923.
7. Pipe zone varies, see Std. Dwg. RD300.

<p><i>The selection and use of this Standard Drawing, while designed in accordance with generally accepted engineering principles and practices, is the sole responsibility of the user and should not be used without first consulting a Registered Professional Engineer.</i></p>		All materials shall be in accordance with the current Oregon Standard Specifications.	
		OREGON STANDARD DRAWINGS	
		PIPE TO STRUCTURE CONNECTIONS	
		2024	
DATE	REVISION	DESCRIPTION	
07-2021	REVIS	NOTES	
04-2022	REVIS	NOTES	
01-2023	REVIS	DETAILS AND NOTES	
CALC. BOOK NO.	N/A	SDR DATE	20-JAN-2023
			RD339

Effective Date: December 1, 2023 – May 31, 2024

20-JUL-2020
RD366.dgn

GENERAL NOTES FOR ALL DETAILS ON THIS SHEET:

- Where precast inlets are used as an alternate to cast-in-place inlets, a 4" compacted leveling bed of sand or 1/4"-0 crushed aggregate shall be provided. All precast inlets shall conform to requirements of ASTM C913.
- Graphics show CG-1 inlet with Type 2 grate. See Table A for inlet dimensions. Type 1 grate allowed only in locations not subject to bicycle or pedestrian use. For frame and grate details, see Std. Dwg. RD365.
- Provide sump only where shown on plans, and allowed by jurisdiction. See Detail B for inlet without sump.
- For curb details, see Std. Dwgs. RD700 & RD701.
- See Std. Dwg. RD336 for tracer wire details, or approved alternate.
- Max. pipe diameter varies with pipe material.
- Location, elevation, diameter, slope, and number of pipe(s) varies, see project plans.
- All concrete shall be commercial grade concrete.
- 3/4" preformed filler (in concrete pavement or gutter only) to extend through thickness of concrete.
- See Std. Dwg. RD363 for gutter transition section, when curb and gutter are required. (Pay limit for inlet is expanded when curb and gutter are monolithic)
- See Std. Dwg. RD339 for pipe to structure connections.

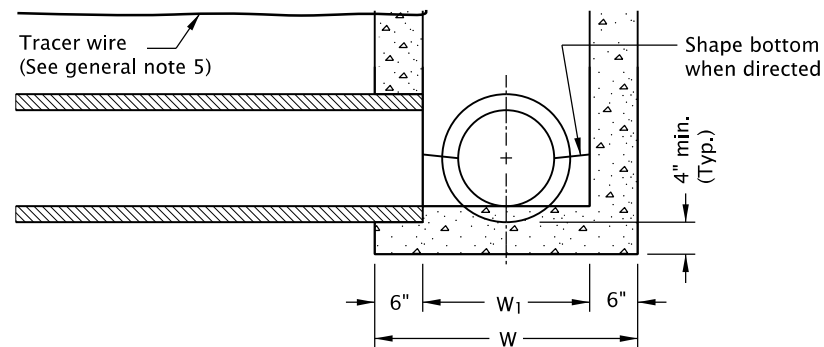

DETAIL B WITH-OUT SUMP

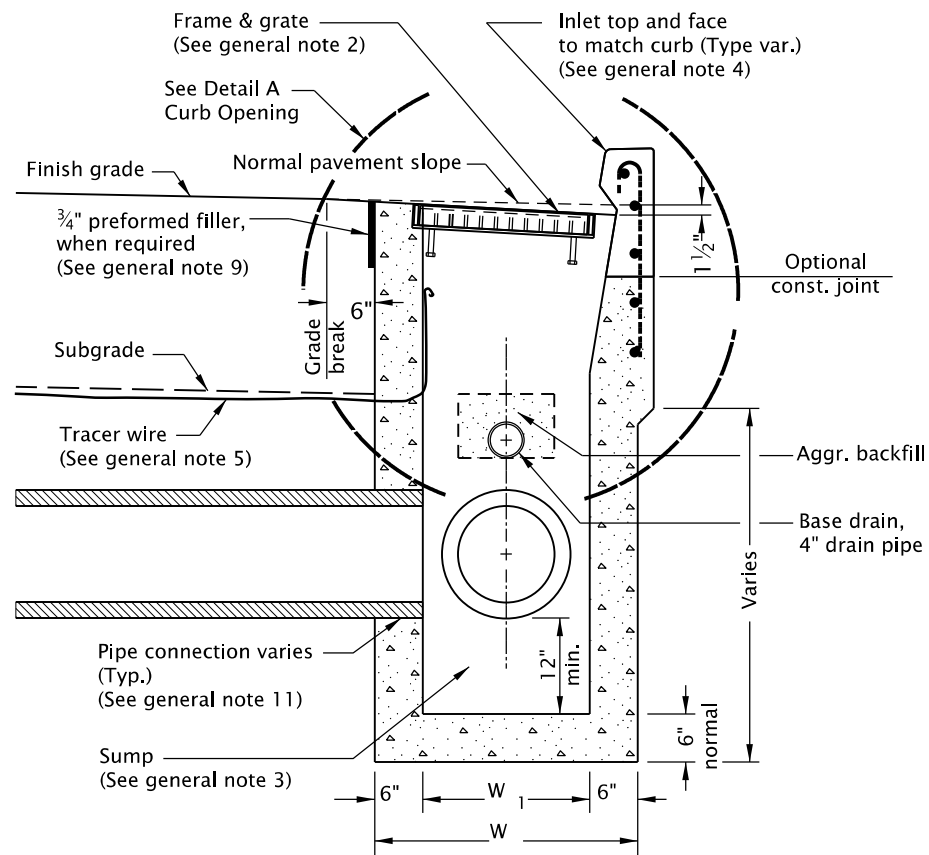

SECTION B - B

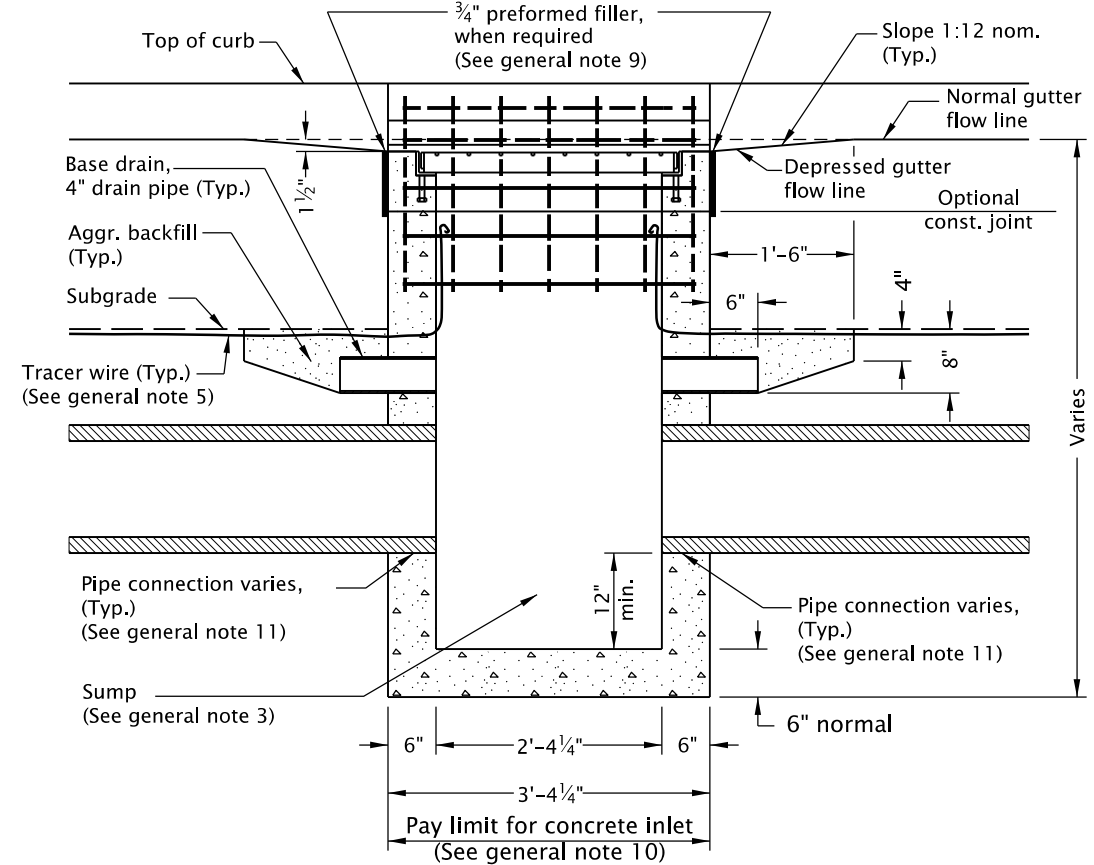

SECTION A - A

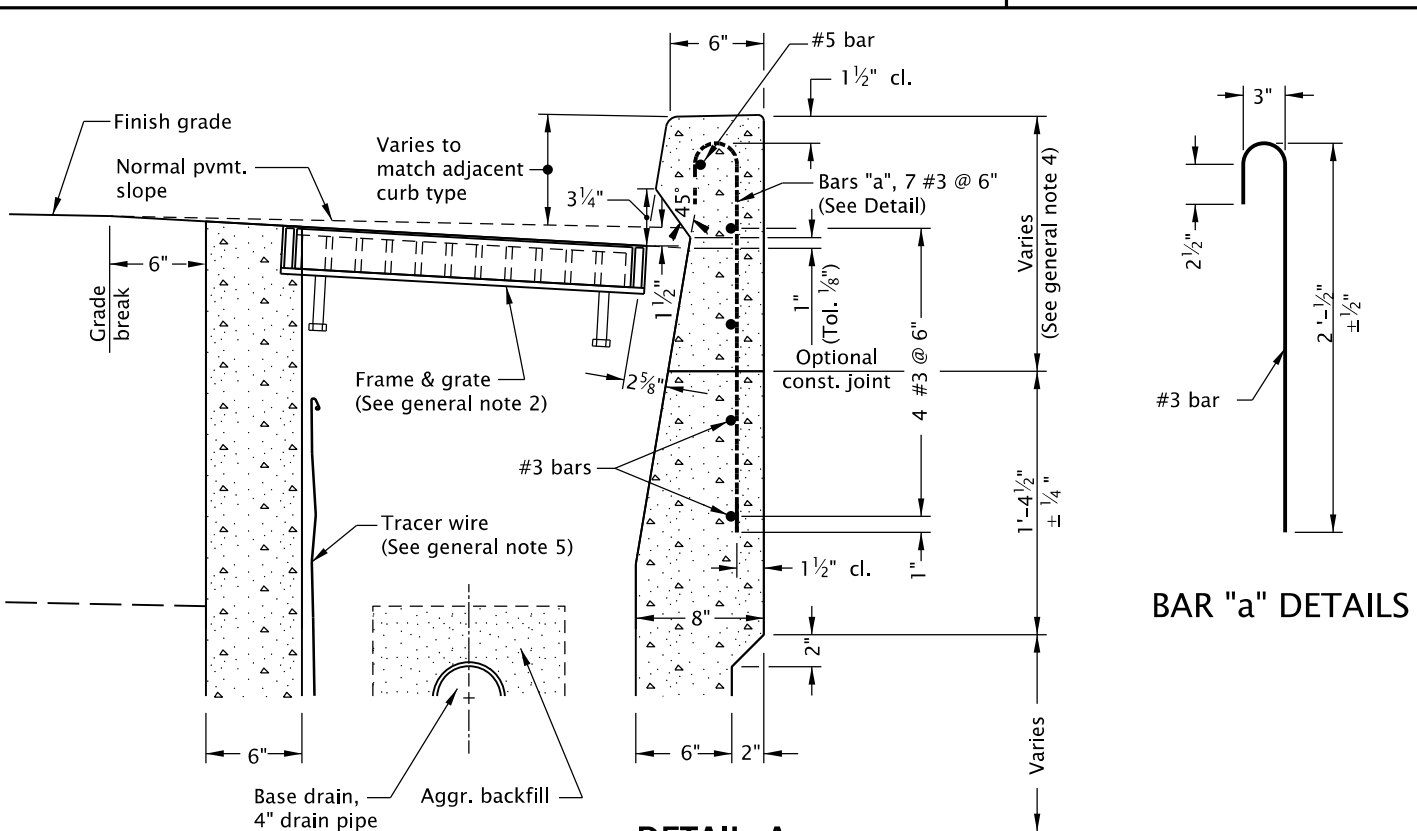

DETAIL A CURB OPENING

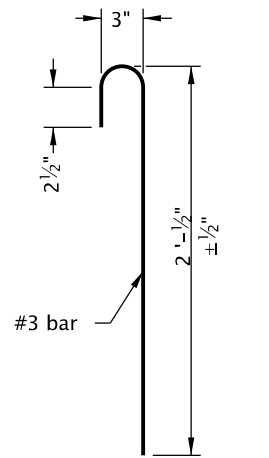

BAR "a" DETAILS

TABLE A		
INLET TYPE	W	W ₁
CG-1	2'-8 7/8"	1'-8 7/8"
CG-2	3'-3 3/8"	2'-3 3/8"

NOTES:

- #3 "a" bars to be placed during curb construction.
- All bars to be placed 1 1/2" clear of nearest face of concrete unless shown or noted otherwise.
- All bars shall be full length.

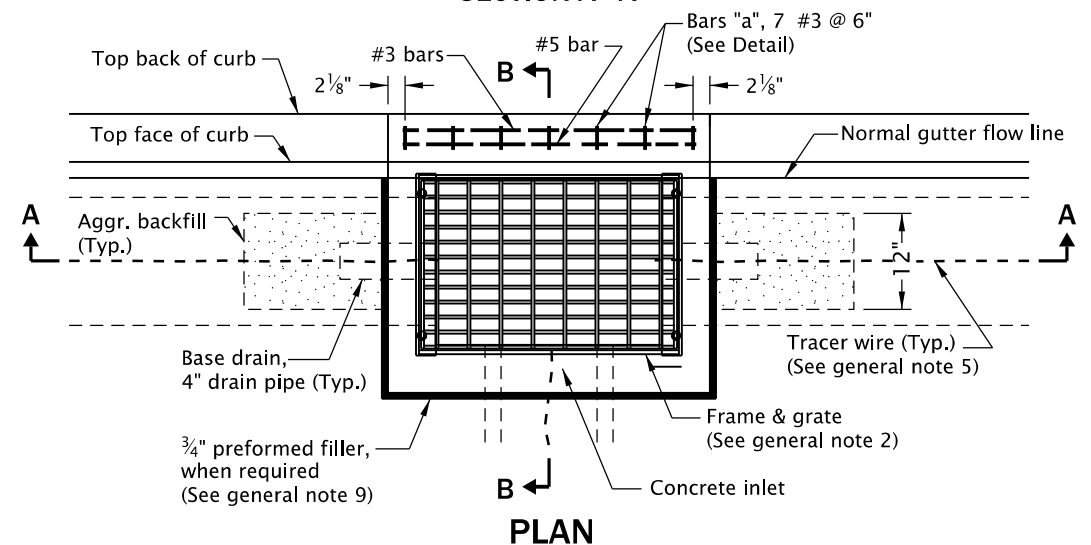

PLAN

NOTE:
Use details shown on Std. Dwg. RD367 when curb inlet channels are used.

The selection and use of this Standard Drawing, while designed in accordance with generally accepted engineering principles and practices, is the sole responsibility of the user and should not be used without first consulting a Registered Professional Engineer.

All materials shall be in accordance with the current Oregon Standard Specifications.

OREGON STANDARD DRAWINGS

CONCRETE INLETS
TYPE CG-1, CG-2

2024

DATE	REVISION	DESCRIPTION

CALC. BOOK NO. ---	N/A ---	SDR DATE --- 20-JUL-2020 ---	RD366
--------------------	---------	------------------------------	--------------

Effective Date: December 1, 2023 – May 31, 2024

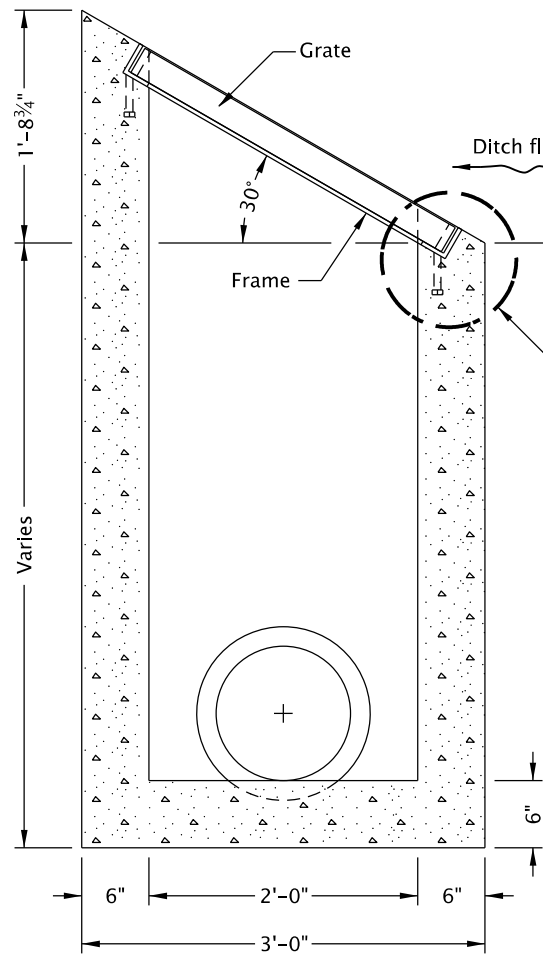

SECTION A - A

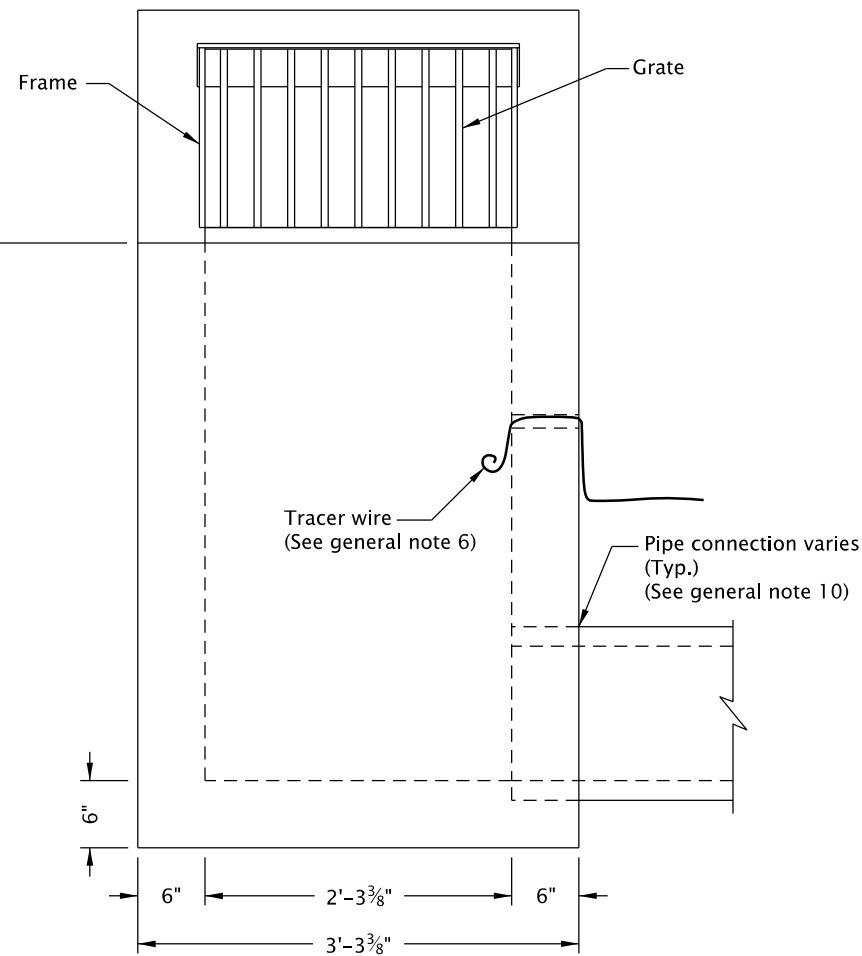

ELEVATION

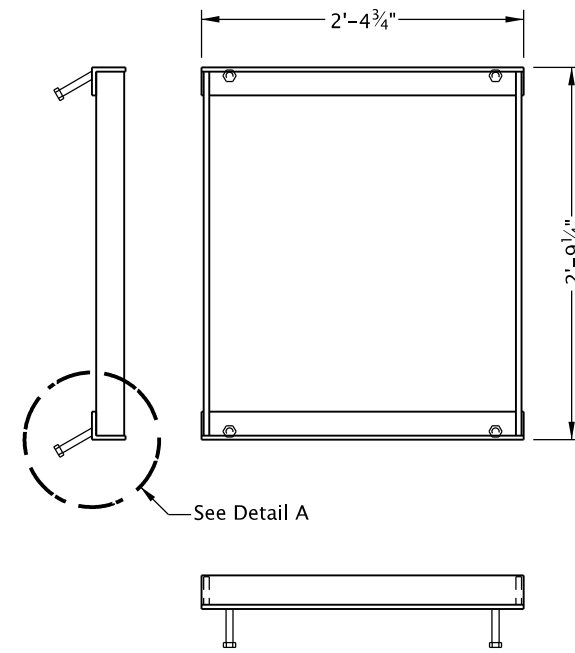

G-2 FRAME
(See general note 2)

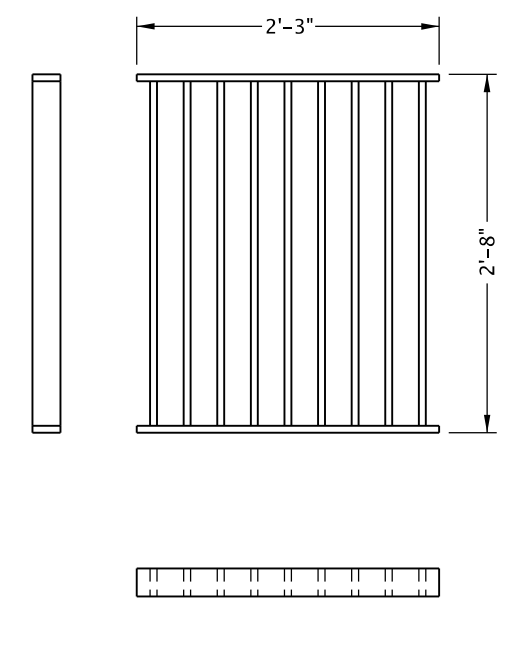

G-2 GRATE (TYPE 1)
(See general note 2)

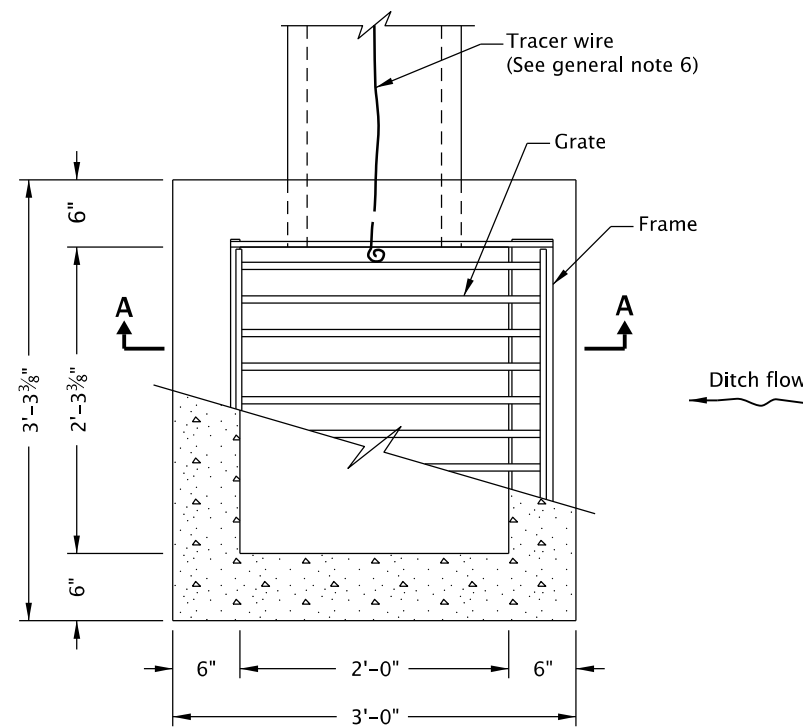

PLAN

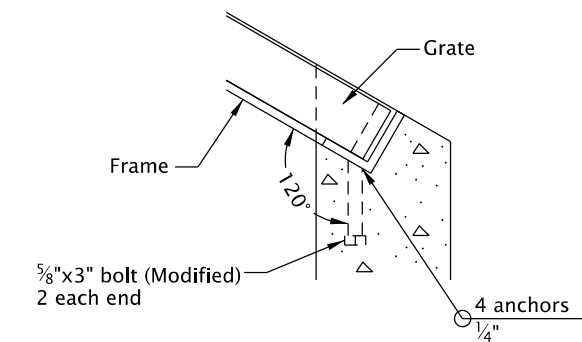

DETAIL A
(Anchor bolt modification, see general note 2)

GENERAL NOTES FOR ALL DETAILS ON THIS SHEET:

1. All concrete shall be commercial grade concrete.
2. For frame & grate details not shown, see Std. Dwg. RD365.
G-2 (Type 2) grates may be used if approved by the engineer.
3. Catch basin, frame, and grates shall meet H2O loading.
4. Provide sump only when shown on plans, and allowed by jurisdiction. For sump details, see Std. Dwg. RD364.
5. 5/8" cross bars shall be flush with the grate surface and may be fillet welded, resistance welded or electroforged to bearing bars.
6. See Std. Dwg. RD336 for tracer wire details, or approved alternate.
7. Max. pipe diameter varies with pipe material.
8. Do not use in locations where inlet can be struck by an errant vehicle, or provide shielding of inlet.
9. Inlet base may be cast-in-place or precast. Where precast inlet base is used as an alternate, a 4" compacted leveling bed of sand or 1/4"-0 crushed aggregate shall be provided.
All precast inlets shall conform to requirements of ASTM C913.
10. See Std. Dwg. RD339 for pipe to structure connections.
11. Location, elevation, diameter, slope, and number of pipe(s) varies, see project plans.

The selection and use of this Standard Drawing, while designed in accordance with generally accepted engineering principles and practices, is the sole responsibility of the user and should not be used without first consulting a Registered Professional Engineer.

All materials shall be in accordance with the current Oregon Standard Specifications.		
OREGON STANDARD DRAWINGS		
DITCH INLET TYPE D		
2024		
DATE	REVISION DESCRIPTION	
CALC. BOOK NO.	N/A	SDR DATE
		21-JUL-2015
		RD370

RD371.dgn 20-JUL-2020

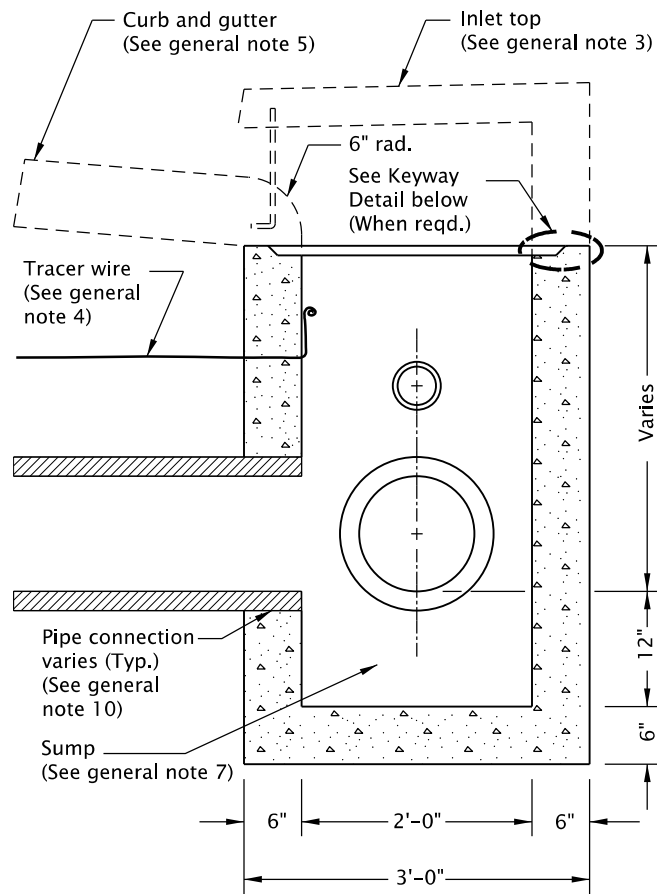

SECTION B - B

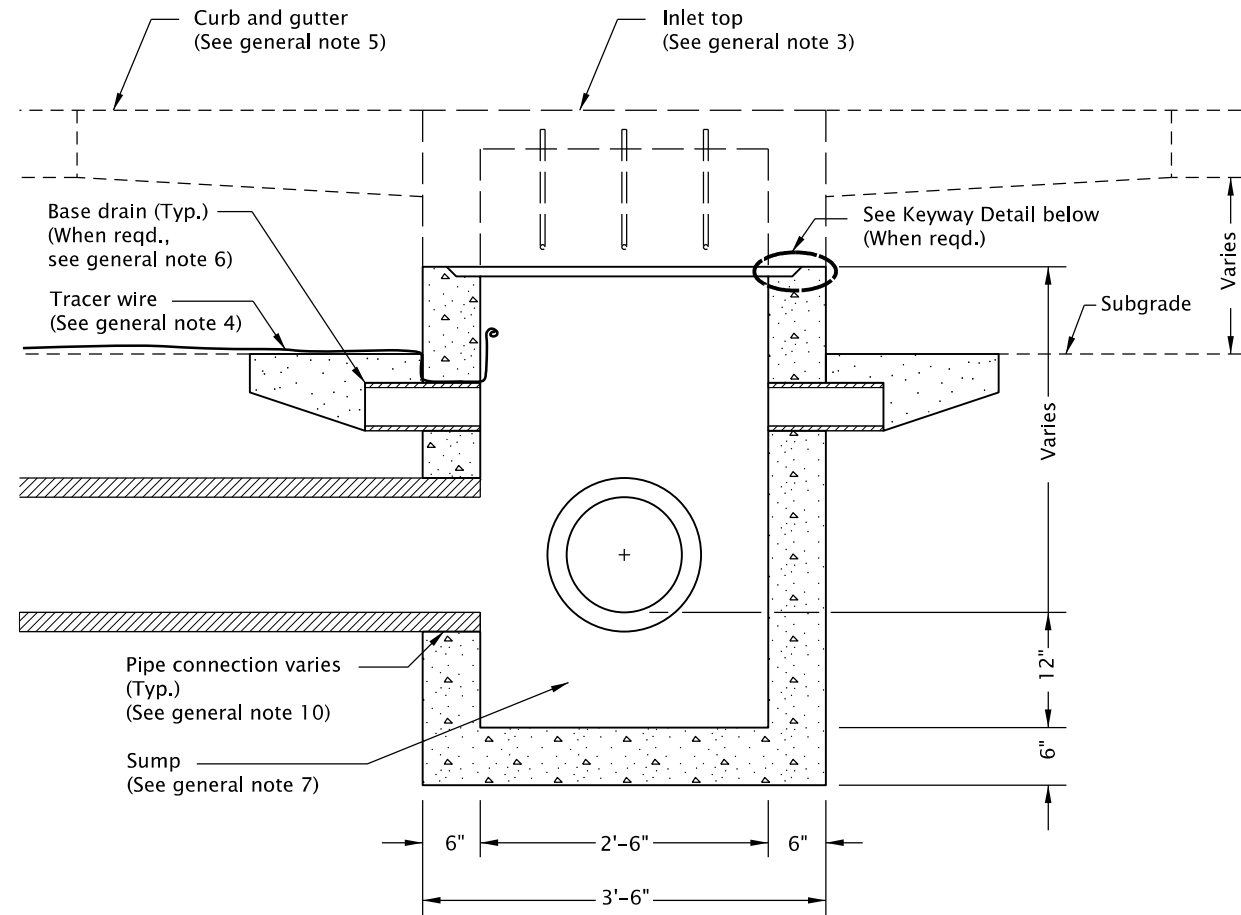

SECTION A - A

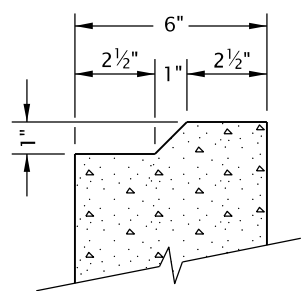

KEYWAY DETAIL

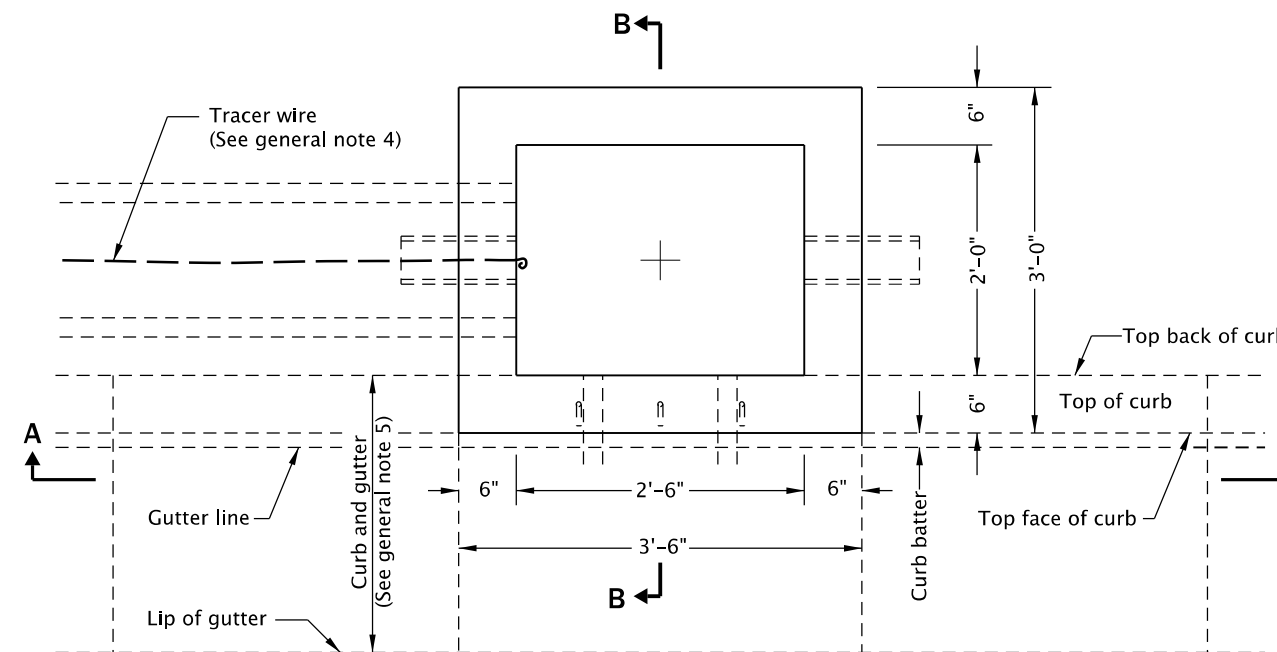

PLAN

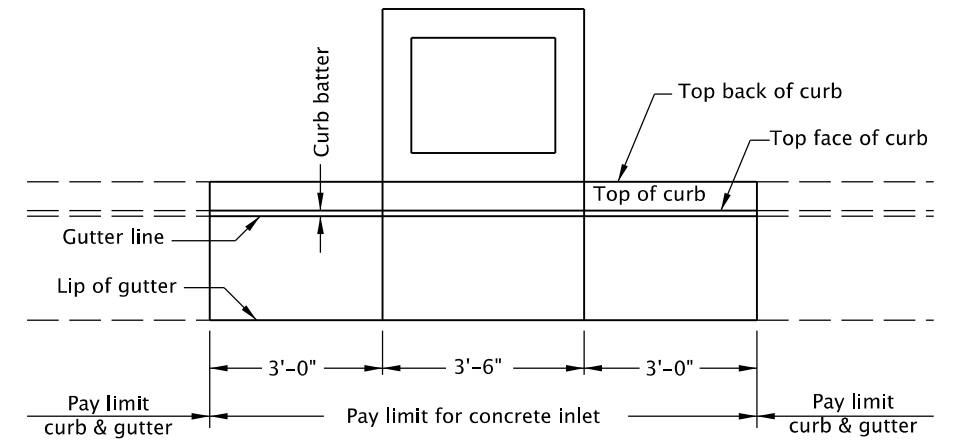

**PLAN
PAY LIMIT**

GENERAL NOTES FOR ALL DETAILS ON THIS SHEET:

1. All concrete shall be commercial grade concrete.
2. Inlet base may be cast-in-place or precast. Where precast inlet base is used as an alternate, a 4" compacted leveling bed of sand or 1/4"-0 crushed aggregate shall be provided. All precast inlets shall conform to requirements of ASTM C913.
3. See Std. Dwg. RD372 & RD373 for inlet top details.
4. See Std. Dwg. RD336 for tracer wire details, or approved alternate.
5. See Std. Dwg. RD700 & RD701 for curb and gutter details.
6. See Std. Dwg. RD364 for base drain details.
7. Provide sump only where shown on plans, and allowed by jurisdiction. For sump details, see Std. Dwg. RD364.
8. Location, elevation, diameter, slope, and number of pipe(s) varies, see project plans.
9. Max. pipe diameter varies with pipe material.
10. See Std. Dwg. RD339 for pipe to structure connections.

The selection and use of this Standard Drawing, while designed in accordance with generally accepted engineering principles and practices, is the sole responsibility of the user and should not be used without first consulting a Registered Professional Engineer.

All materials shall be in accordance with the current Oregon Standard Specifications.			
OREGON STANDARD DRAWINGS			
CONCRETE INLET BASE TYPE CG-3			
2024			
DATE	REVISION DESCRIPTION		
CALC. BOOK NO.	N/A	SDR DATE	21-JUL-2015
			RD371

Effective Date: December 1, 2023 – May 31, 2024

20-JUL-2020

RD700.dgn

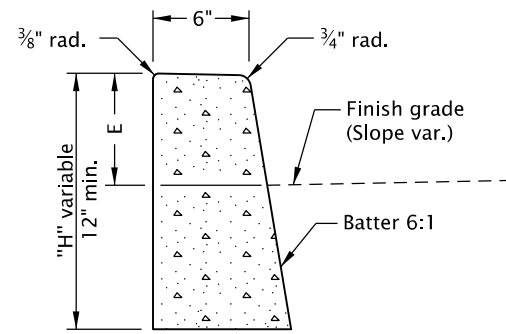

O.D.O.T. & City of Portland Standard "H"=16" STANDARD CURB
(See general note 11)

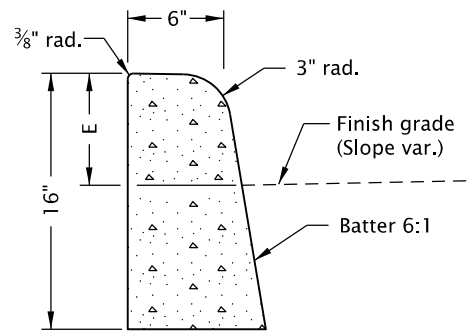

MOUNTABLE CURB
(See general note 11)

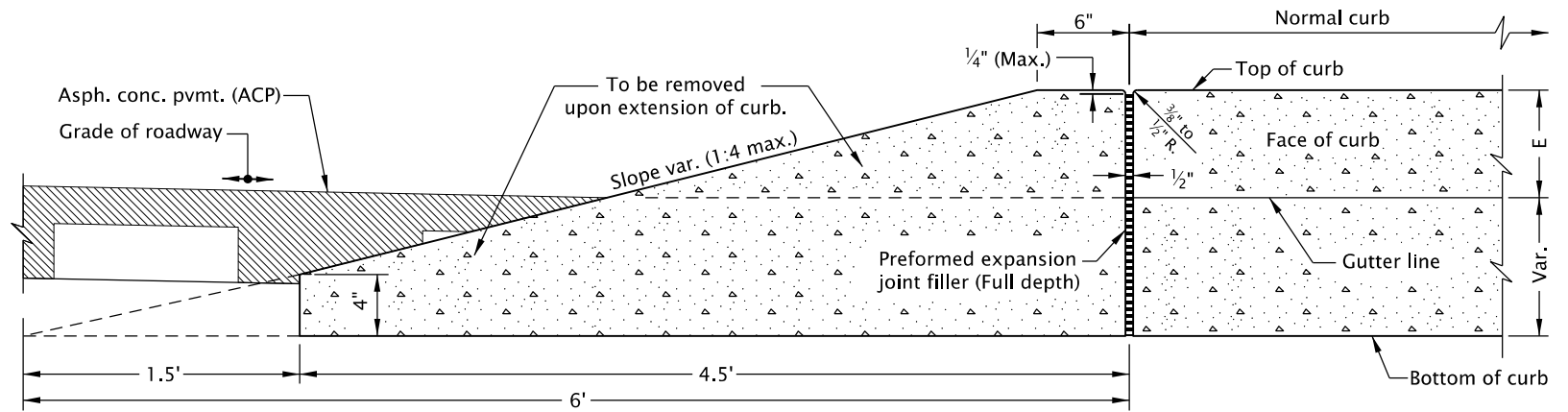

CURB ENDING DETAIL

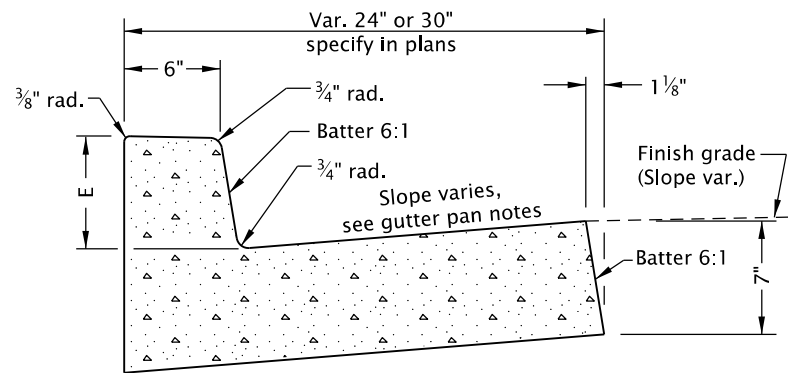

CURB AND GUTTER

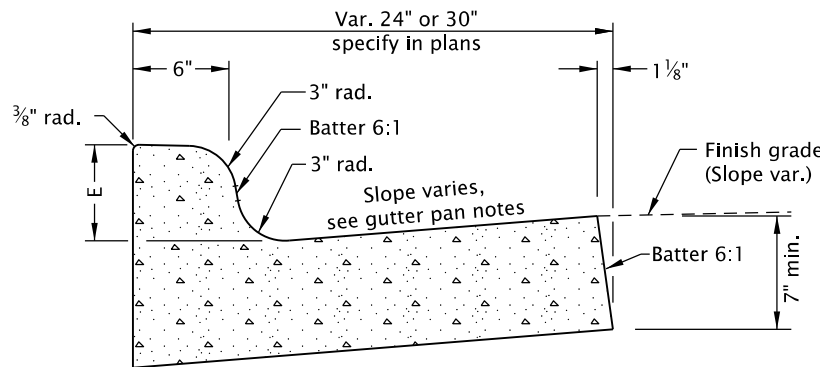

MOUNTABLE CURB AND GUTTER

GUTTER PAN NOTES:
Slope 5.0% normal.
Slope 4.0% max. at curb ramps.
Vary slope as reqd. for drainage.
Vary where shown on plans, and allowed by jurisdiction.

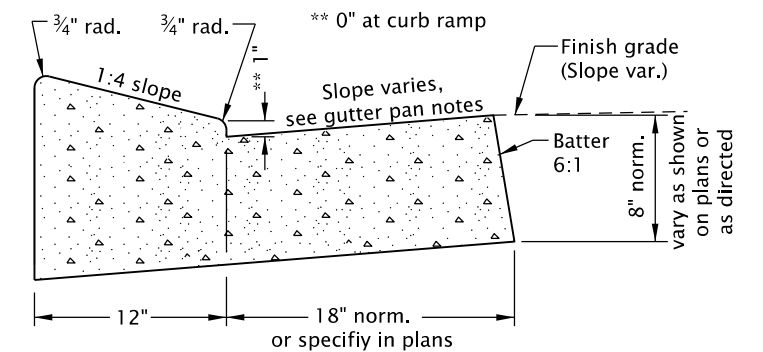

LOW PROFILE MOUNTABLE CURB AND GUTTER
(Where shown on plans)

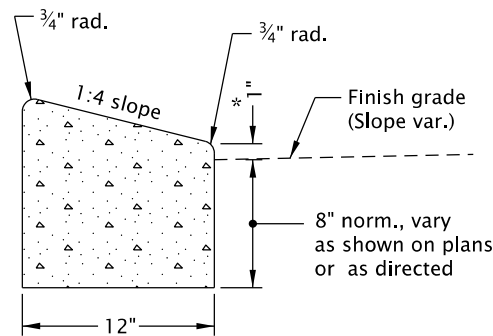

* 0" for Truck Apron

LOW PROFILE MOUNTABLE CURB
(See general note 11)

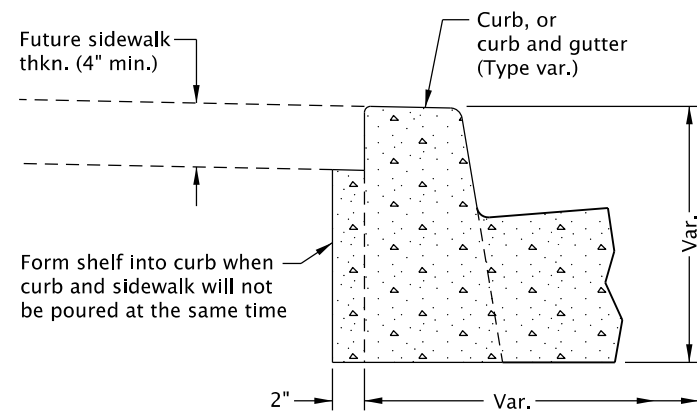

MODIFICATION FOR KEYWAY
(Where shown on plans)

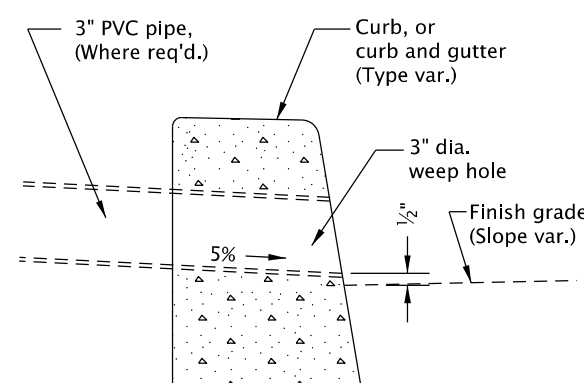

WEEP HOLE DETAIL
(Where shown on plans, and allowed by jurisdiction)

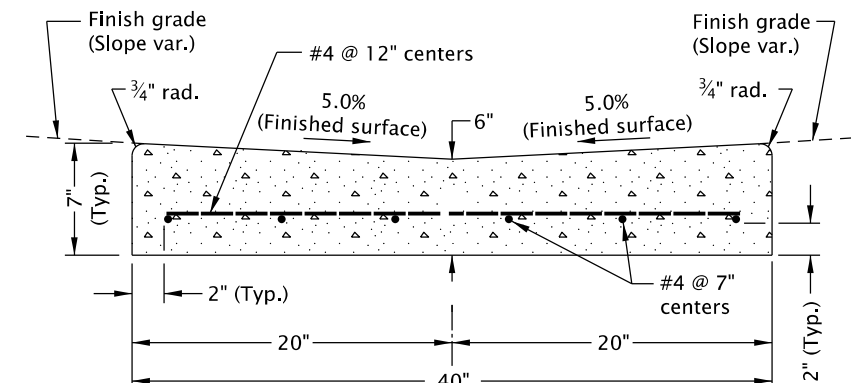

VALLEY GUTTER

GENERAL NOTES FOR ALL DETAILS ON THIS SHEET:

1. Curb exposure "E" = 6" to 9", as measured vertically from flowline to highest point on curb. Vary as shown on plans or as directed. O.D.O.T standard "E"=7".
2. Const. curb expansion joints at 200' maximum spacing, and at points of tangency, and at ends of each driveways.
3. Const. curb contraction joints at 15' maximum spacing, and at ends of each inlet and curb ramp.
4. Transitions shall be used to connect curbs of different exposures "E". ("E" Is the total vertical dimension of those curb surfaces having a slope of 1:1 or steeper). Minimum desirable transition length shall be 20' for each 1" difference in "E".

5. Tops of all curbs shall slope toward the roadway at 1.5% max. (Max. 2.0% finished surface slope), unless otherwise shown, or as directed.
6. Dimensions are nominal, vary to conform with curb machine approved by the engineer.
7. Dimensions adjacent to radii are measured to the point of intersection of curb surfaces.
8. For sidewalk details, and monolithic curb & sidewalk, see Std. Dwgs. RD720 & RD721.
9. For drainage curbs, see Std. Dwg. RD701.
10. For curb ramp details, see Std. Dwgs. RD900 series.
11. On or along state highways, curb and gutter is required at curb ramp.

The selection and use of this Standard Drawing, while designed in accordance with generally accepted engineering principles and practices, is the sole responsibility of the user and should not be used without first consulting a Registered Professional Engineer.

All materials shall be in accordance with the current Oregon Standard Specifications.

OREGON STANDARD DRAWINGS

CURBS

2024

DATE	REVISION	DESCRIPTION

CALC. BOOK NO. --- N/A --- SDR DATE: 20-JUL-2020 **RD700**

Effective Date: December 1, 2023 – May 31, 2024

20-JUL-2020

RD720.dgn

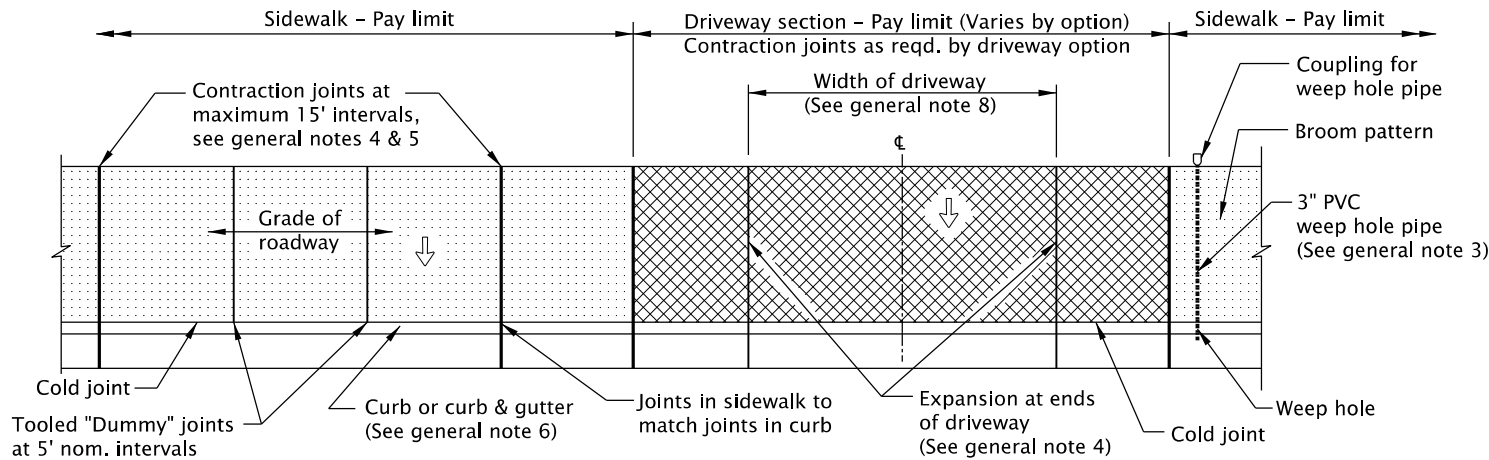

TYPICAL PLAN VIEW - CURB LINE SIDEWALK

*** Objects with base below 2'-3" may protrude any distance as long as the 5' circulation path is maintained. When an object with a base higher than 2'-3" protrudes further than 4" provide a detection below protrusion to delineate edge.

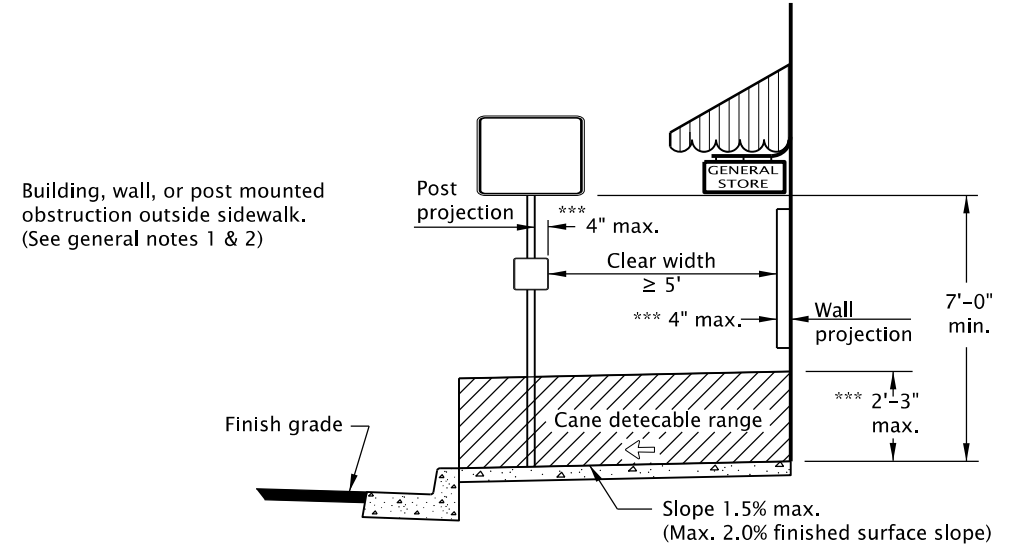

CLEAR CIRCULATION PATH

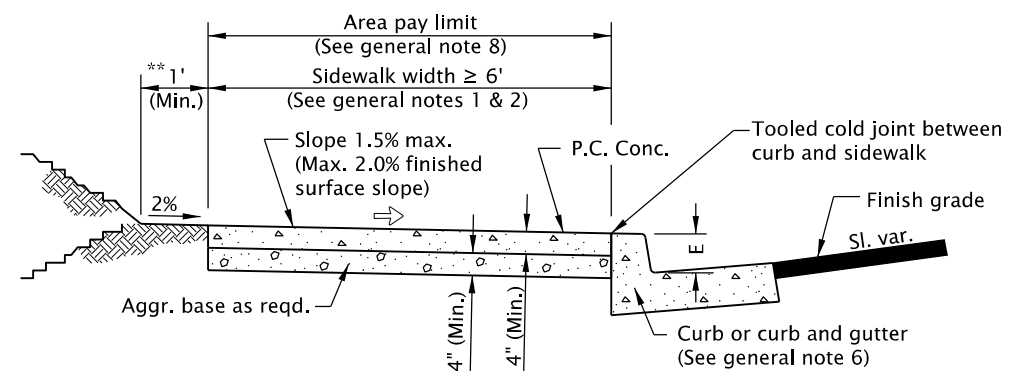

TYPICAL CURB SIDEWALK CROSS SECTION

* Min. 4" or as specified in plans. A thickness $\geq 6"$ if sidewalk is intended as portion of a driveway or mountable curb is used.

** Provide compacted backfill adjacent to curb and sidewalk

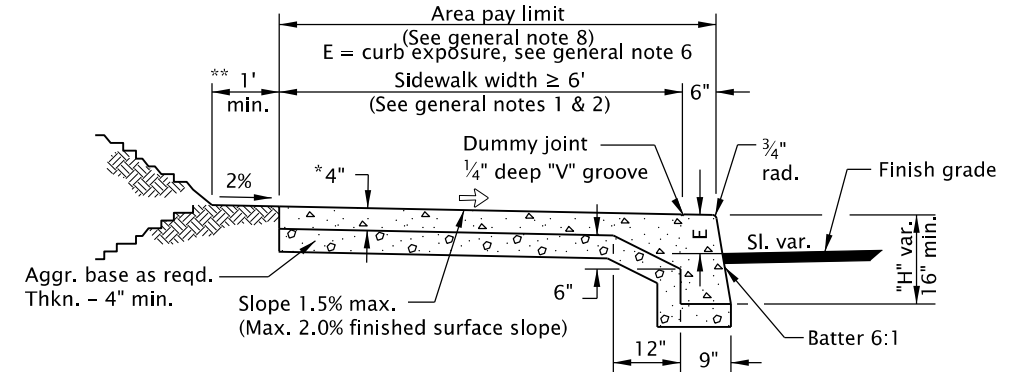

TYPICAL MONOLITHIC CURB & SIDEWALK CROSS SECTION

E = curb exposure, see general note 6

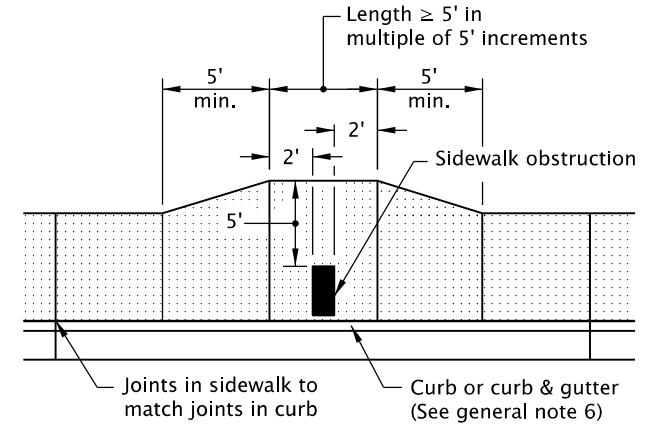

REQUIRED SIDEWALK WIDENING AROUND OBSTRUCTIONS

GENERAL NOTES FOR ALL DETAILS ON THIS SHEET:

1. Include additional paved or unpaved 2' shy distance to vertical faces higher than 5' such as retaining walls, sound walls, fences and buildings.
2. Curb type and sidewalk width as shown on plans or as directed. On sidewalks 8' and wider, provide a longitudinal joint at the midpoint.
3. Install 3" pvc weep hole pipes in sidewalks where shown on plans, and allowed by jurisdiction. Place contraction joint over top of pipe. See Std. Dwg. RD700 for weep hole details.
4. Provide expansion joints around poles, posts, boxes, at ends of each driveway, and other fixtures which protrude through or against the structures. For sidewalk, monolithic curb & sidewalk, const. expansion joints at 45' maximum spacing. See Std. Dwg. RD722 for expansion joints details.
5. Const. contraction joints at 15' maximum spacing, and at ends of each curb ramp. See Std. Dwg. RD722 for contraction joints details.
6. For curb details, see Std. Dwgs. RD700 & RD701. ODOT standard E=7".

7. Sidewalk details are based on applicable ODOT standards.
8. Fully lowered sidewalk shown; see project plans for the driveway design specified. For driveway details not shown, see Std. Dwgs. RD725, RD730, RD735, RD740, RD745 & RD750.
9. See project plans for details not shown.

LEGEND

- Sidewalk pay limit.
- Driveway pay limit, varies by option, (See general note 8).
- Cross slope 1.5% max. (Max. 2.0% finished surface slope) (Normal sidewalk cross slope)

The selection and use of this Standard Drawing, while designed in accordance with generally accepted engineering principles and practices, is the sole responsibility of the user and should not be used without first consulting a Registered Professional Engineer.

All materials shall be in accordance with the current Oregon Standard Specifications.			
OREGON STANDARD DRAWINGS			
CURB LINE SIDEWALKS			
2024			
DATE	REVISION DESCRIPTION		
CALC. BOOK NO.	N/A	SDR DATE	21-JUN-2019
			RD720

Effective Date: December 1, 2023 – May 31, 2024

08-JUL-2022

RD722.dgn

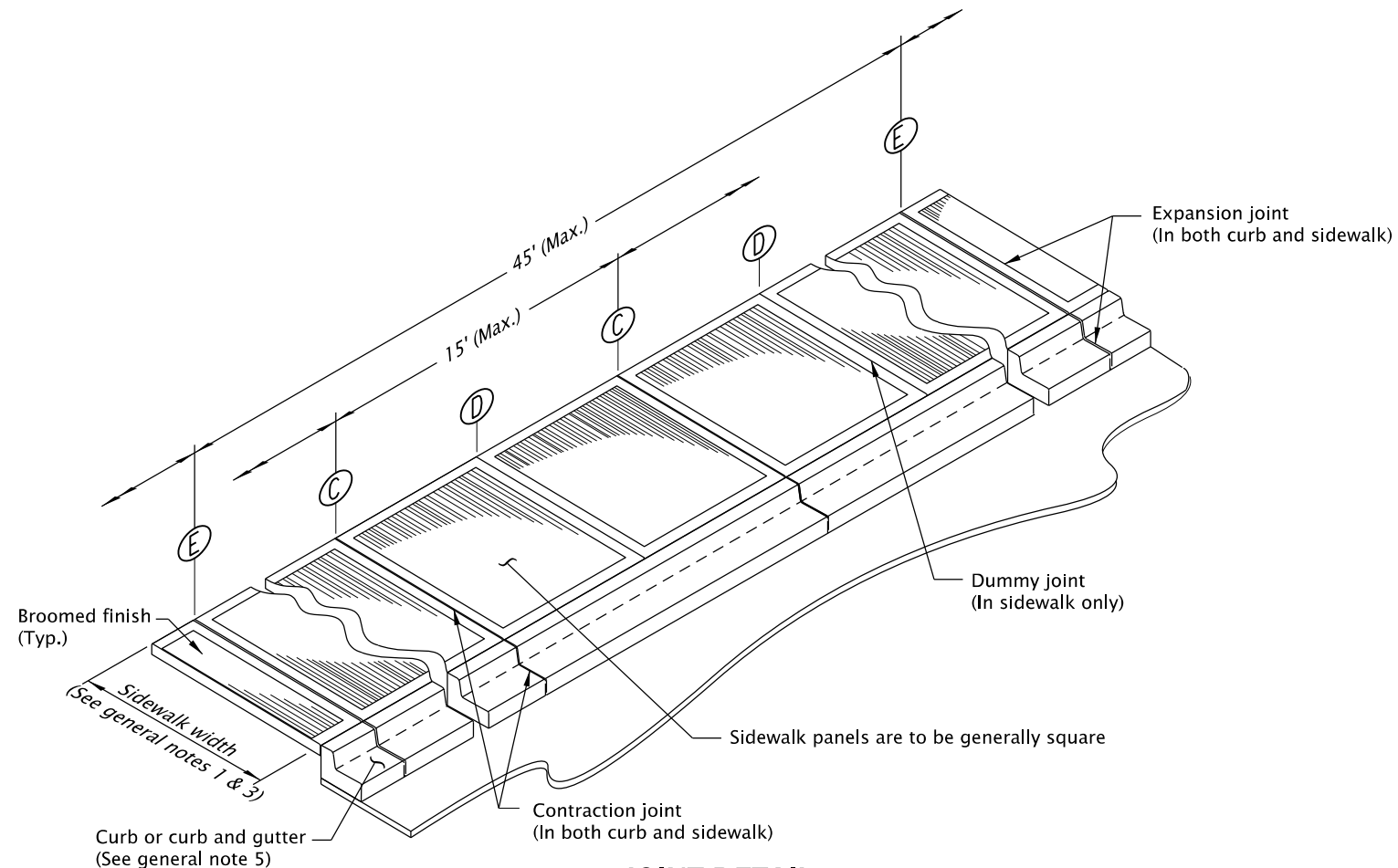

JOINT DETAIL
(Curb line sidewalk with curb and gutter shown)

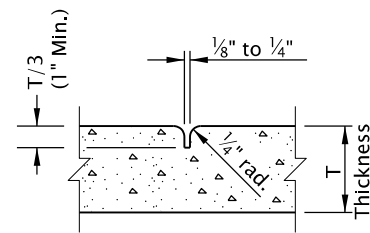

C CONTRACTION JOINT
(See general note 6)

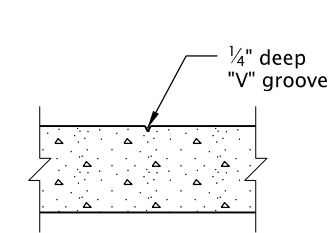

D DUMMY JOINT

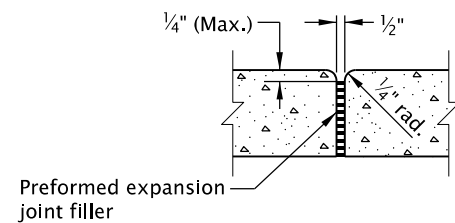

E EXPANSION JOINT
(See general notes 2 & 5)

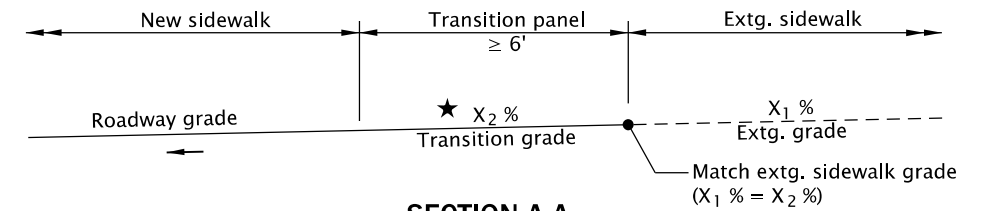

SECTION A-A
(SIDEWALK TRANSITION PANEL SHOWN)

★ Project the existing sidewalk profile grade through transition panel to new sidewalk or curb ramp run.

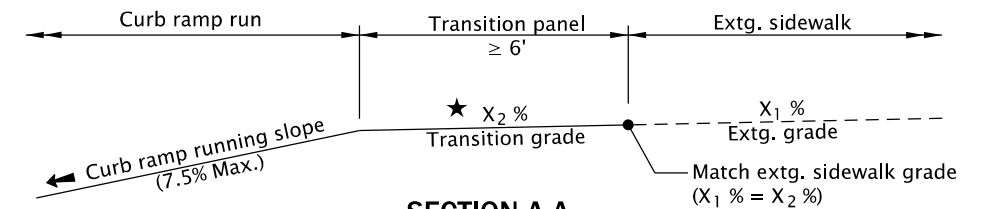

SECTION A-A
(CURB RAMP TRANSITION PANEL SHOWN)

Rate of cross slope change is $\leq 0.5\%$ per foot
Horiz. taper rate change { 1:10 preferred
1:5 constrained
1:3 min.

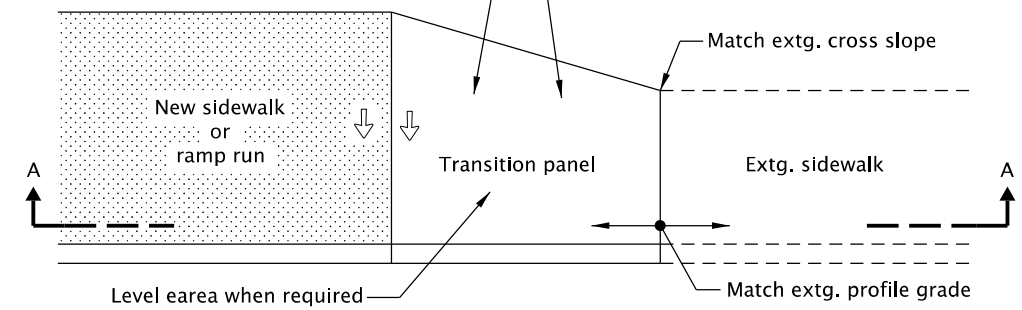

PLAN

SIDEWALK AND CURB RAMP TRANSITION PANELS

GENERAL NOTES FOR ALL DETAILS ON THIS SHEET:

1. See Std. Dwgs. RD720 and RD721 for concrete sidewalk details. See project plans for sidewalk width, placement and design specified.
2. Provide expansion joints around poles, boxes, at ends of each driveway and other fixtures which protrude through or against the structures. For sidewalk, monolithic curb and sidewalk, provide construction expansion joints at 45 feet maximum spacing.
3. On sidewalks 8 feet and wider, provide a longitudinal joint at the midpoint of sidewalk panel.
4. See Std. Dwgs. RD700 and RD701 for concrete curb details. See project plans for the curb design specified.
5. Do not place expansion joints between separate concrete pours for curb ramp system components construction. Place expansion joints outside of curb ramp runs when required. Install expansion joints flush with surface for structures protruding through the curb ramp system. See Std. Dwg. RD900.
6. Construct contraction joints at 15 feet maximum spacing, and at each curb ramp, driveway, sidewalk and curb.

LEGEND:

- New sidewalk or ramp run
- Slope 1.5% max.
(Max. 2.0% finished surface slope)
(Normal sidewalk cross slope)
- Slope 7.5% max.
(Max. 8.3% finished surface slope)
- Zero exposure

The selection and use of this Standard Drawing, while designed in accordance with generally accepted engineering principles and practices, is the sole responsibility of the user and should not be used without first consulting a Registered Professional Engineer.

All materials shall be in accordance with the current Oregon Standard Specifications.

OREGON STANDARD DRAWINGS

SIDEWALK JOINTS AND TRANSITION PANELS

2024

DATE	REVISION	DESCRIPTION
07-2022	REVISED NOTES	
CALC. BOOK NO.	N/A	SDR DATE
		08-JUL-2022











RD722

Effective Date: December 1, 2023 – May 31, 2024

CURB RAMP INDEX

STD. DWG. NO.	STD. DWG. TITLE
RD900	Curb Ramp Components And Legend
RD901	Curb Ramp Legend And Corner Identification
RD902	Detectable Warning Surface Details
RD904	Detectable Warning Surface Placement For Curb Ramps
RD905	Detectable Warning Surface Placement For Directional Curbs
RD906	Detectable Warning Surface Placement For Accessible Route Island
RD908	Detectable Warning Surface Placement
RD909	Detectable Guide Strip Placement At Bike Ramps
RD910, RD912	Perpendicular Curb Ramp
RD913	Perpendicular Curb Ramp With Closure
RD916	Perpendicular Curb Ramp Single Ramp
RD920	Parallel Curb Ramp
RD922	Parallel Curb Ramp Single Ramp
RD930, RD932 & RD936	Combination Curb Ramp
RD938	Combination Curb Ramp Single Ramp
RD940	Blended Transition Curb Ramp Single Ramp
RD950 & RD952	End Of Walk Curb Ramp
RD960	Unique Curb Ramp

LEGEND:

-  Marked or intended crossing location
-  Sidewalk or other traversable surface
-  Detectable warning surface (DWS)
-  Level area (Turning space/landing)
-  Cross slope 1.5% max.
(Max. 2.0% finished surface slope)
(Normal sidewalk cross slope)
-  Running slope 4.0% max.
(Max. 4.9% finished surface slope)
-  Running slope 7.5% max.
(Max. 8.3% finished surface slope)
-  Counter slope 4.0% max. ascending or descending
(Max. 5.0% finished surface slope)
Slope as required for drainage
-  Flare slope
(Max. 10.0% finished surface slope)
-  4'x4' clear space
- RR1 Ramp Run Position 1

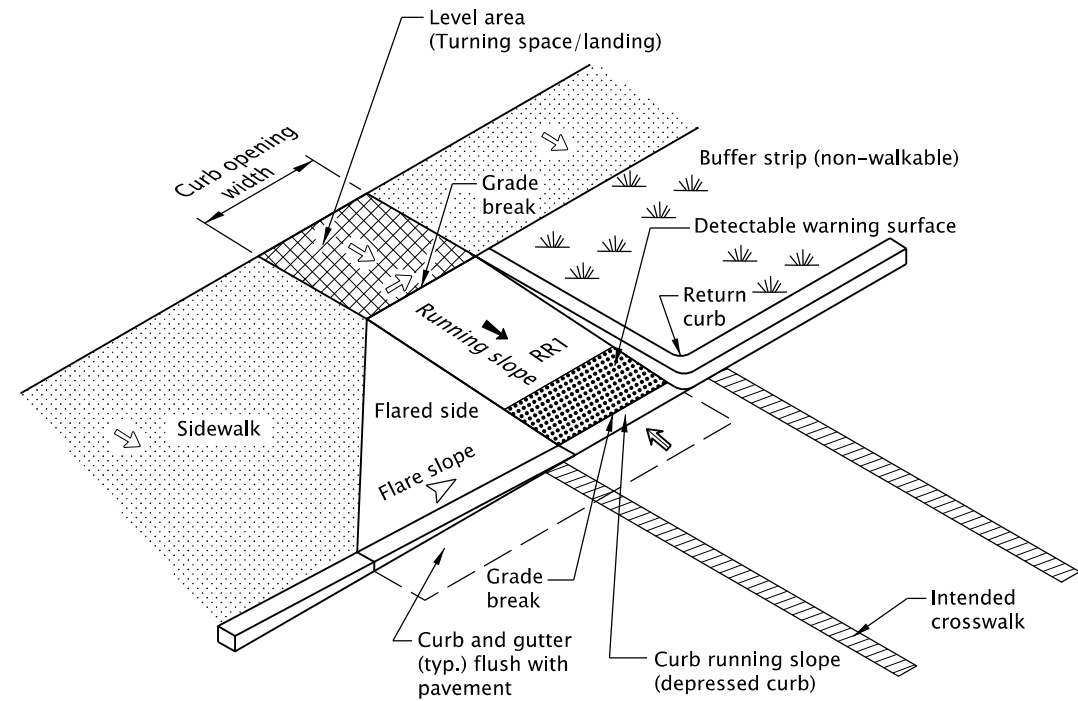

TYPICAL CURB RAMP SYSTEM COMPONENTS
(PERPENDICULAR TYPE SHOWN)

<p><i>The selection and use of this Standard Drawing, while designed in accordance with generally accepted engineering principles and practices, is the sole responsibility of the user and should not be used without first consulting a Registered Professional Engineer.</i></p>		All materials shall be in accordance with the current Oregon Standard Specifications.	
		OREGON STANDARD DRAWINGS	
		CURB RAMP COMPONENTS AND LEGEND	
		2024	
DATE	REVISION	DESCRIPTION	
07-2020	NEW DRAWING CREATED		
07-2021	REVISED DETAILS AND NOTES		
01-2022	REVISED LEGEND		
CALC. BOOK NO.	N/A	SDR DATE- 14-JAN-2022	RD900

19-JUL-2021

RD902.dgn

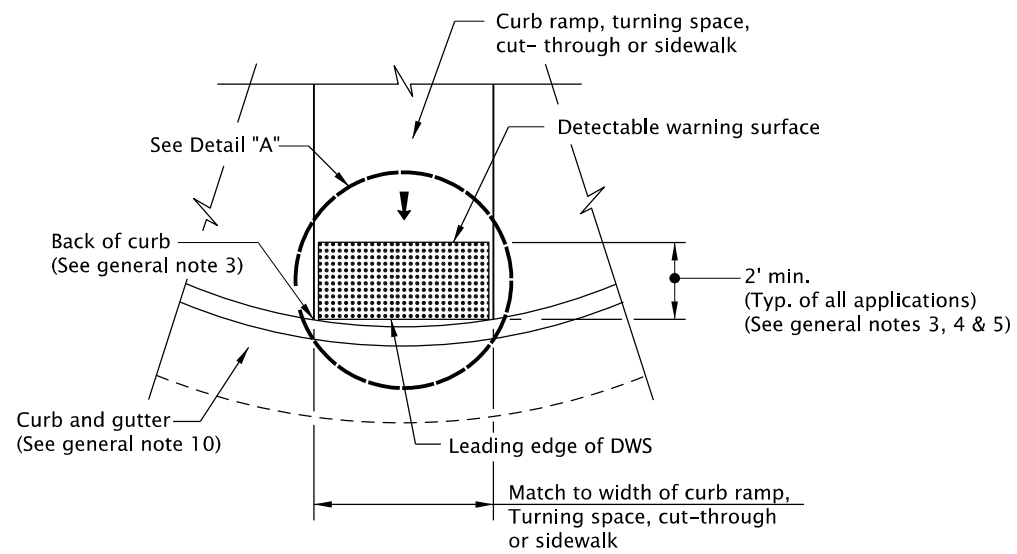

DETECTABLE WARNING SURFACE DETAIL

	A	B	C	D	E
MIN.	1.60"	0.65"	0.45"	0.90"	0.20"
MAX.	2.40"	--	0.91"	1.40"	0.20"

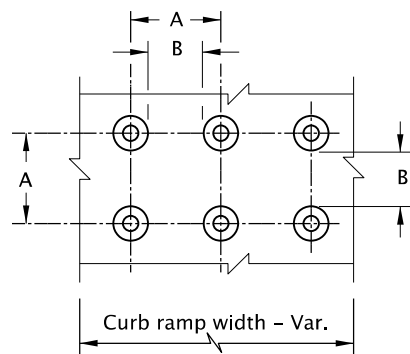

TRUNCATED DOME SPACING

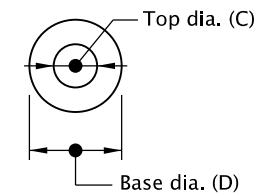
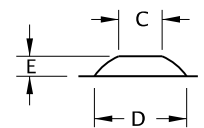

TRUNCATED DOME

TRUNCATED DOME DETAILS

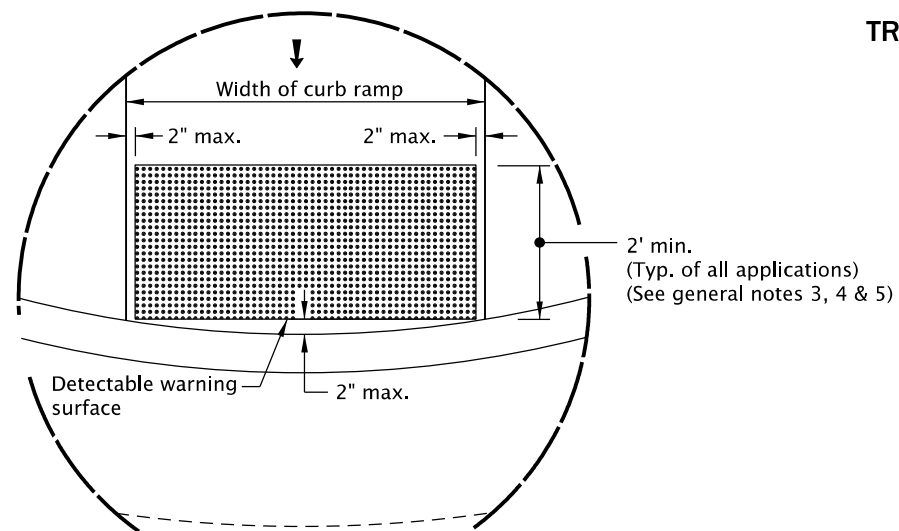



DETAIL "A"

GENERAL NOTES FOR ALL DETAILS ON THIS SHEET:

1. Detectable warning surface details & locations are based on applicable ODOT Standards.
2. See project plans for details not shown. See Std. Dwgs. RD700 & RD701 for curbs.
3. The detectable warning surface shall extend the full width of the curb ramp opening, shared use path, blended transition, turning space, or other roadway entrance as applicable. A gap of up to 2 inches on each side of the detectable warning surface is permitted (measured at the leading edge of the detectable warning surface panel as shown in Detail "A").
4. Detectable warning surface shall be placed at the back of curb for a minimum depth of 2 ft. in the direction of pedestrian travel at curb ramps that are adjacent to traffic. Detectable warning surface may be radial or rectangular, but must comply with the truncated dome size and spacing standards. Detectable warning surface across a grade break is prohibited. Place abutting panels within 1/4 inch of each other and install anchors, as specified by manufacturers, along cut edge.
5. Color to be safety yellow if no color specified in construction note. Alternative colors require a design exception on or along state highways.
6. Detectable warning surface shall be used in the following locations:
 - a) Curb ramps at street crossings.
 - b) Crossing islands (Accessible Route Islands).
 - c) Rail crossings.
7. Where public transportation stations (rail, bus, etc.) use platform boarding, detectable warning surface shall be placed along the full edge length of the station, when not protected by platform screens or guards, (see Std. Dwg. RD908).
8. Detectable warning surface shall not be used on the following locations:
 - a) End of sidewalk transitions that are not at a crosswalk, (see Std. Dwgs. RD950, RD952 and RD960).
 - b) Driveways, unless constructed with curb return or are signalized.
 - c) Parking lots, access aisles and passenger loading zones where curb ramp does not lead to vehicular way.
9. Where no curb is present, the detectable warning surface shall be placed at the edge of the roadway.
10. On or along state highways, curb and gutter is required at curb ramps.

LEGEND:

-  Detectable warning surface
-  Cross slope 1.5% max. (Max. 2.0% finished surface slope) (Normal sidewalk cross slope)
-  Running slope 7.5% max. (Max. 8.3% finished surface slope)

The selection and use of this Standard Drawing, while designed in accordance with generally accepted engineering principles and practices, is the sole responsibility of the user and should not be used without first consulting a Registered Professional Engineer.

All materials shall be in accordance with the current Oregon Standard Specifications.

OREGON STANDARD DRAWINGS

DETECTABLE WARNING SURFACE DETAILS

2024

DATE	REVISION	DESCRIPTION
07-2020	NEW DRAWING CREATED	
07-2021	REVISED DETAILS AND NOTES	

CALC. BOOK NO. ---	N/A ---	SDR DATE- 19-JUL-2021	RD902
--------------------	---------	-----------------------	--------------

Effective Date: December 1, 2023 – May 31, 2024

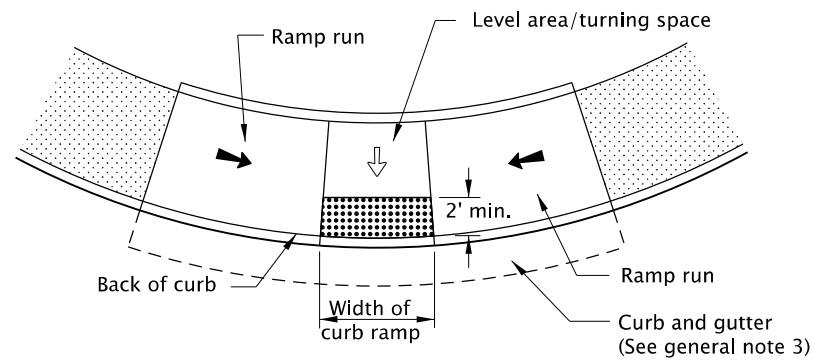

PARALLEL CURB RAMP

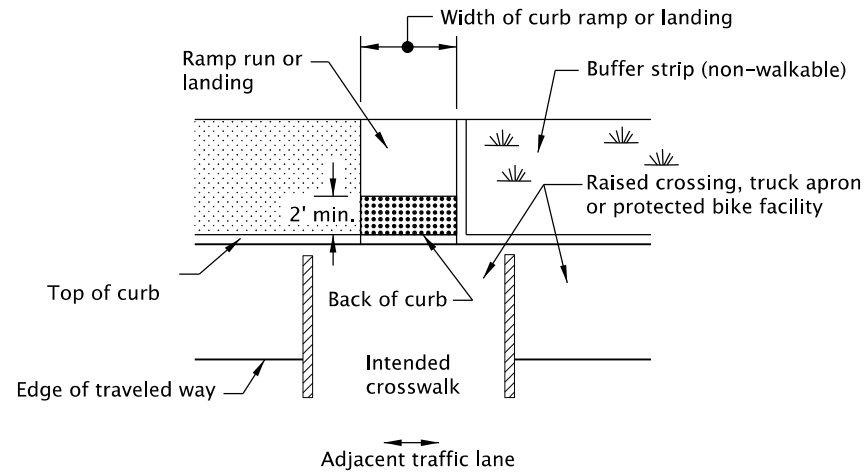

RAISED CROSSING, TRUCK APRON OR PROTECTED BIKE FACILITY

GENERAL NOTES FOR ALL DETAILS ON THIS SHEET:

1. Detectable warning surface details & locations are based on applicable ODOT Standards.
2. See project plans for details not shown.
See Std. Dwgs. RD700 & RD701 for curbs.
See Std. Dwg. RD902 for detectable warning surface installation details.
3. On or along state highways, curb and gutter is required at curb ramps.
4. Detectable warning surface placement for perpendicular ramps vary as shown.

LEGEND:

- Marked or intended crossing location
- Sidewalk
- Detectable warning surface
- Cross slope 1.5% max.
(Max. 2.0% finished surface slope)
(Normal sidewalk cross slope)
- Running slope 7.5% max.
(Max. 8.3% finished surface slope)

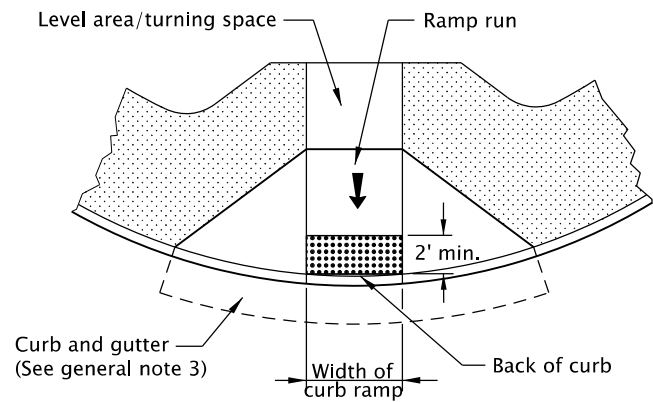

**PERPENDICULAR CURB RAMP
GRADE BREAK IN FRONT OF CURB**

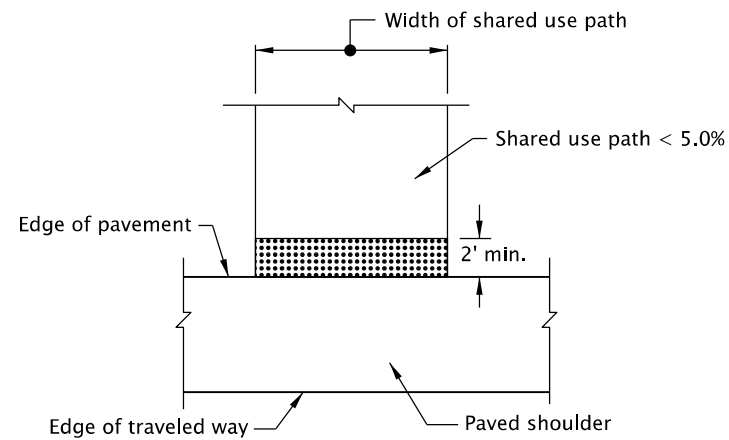

SHARED-USE PATH CONNECTION

The selection and use of this Standard Drawing, while designed in accordance with generally accepted engineering principles and practices, is the sole responsibility of the user and should not be used without first consulting a Registered Professional Engineer.

All materials shall be in accordance with the current Oregon Standard Specifications.

OREGON STANDARD DRAWINGS

DETECTABLE WARNING SURFACE PLACEMENT FOR CURB RAMPS

2024

DATE	REVISION	DESCRIPTION
07-2020	NEW DRAWING CREATED	
CALC. BOOK NO.	N/A	SDR DATE

RD904

14-JAN-2022

RD920.dgn

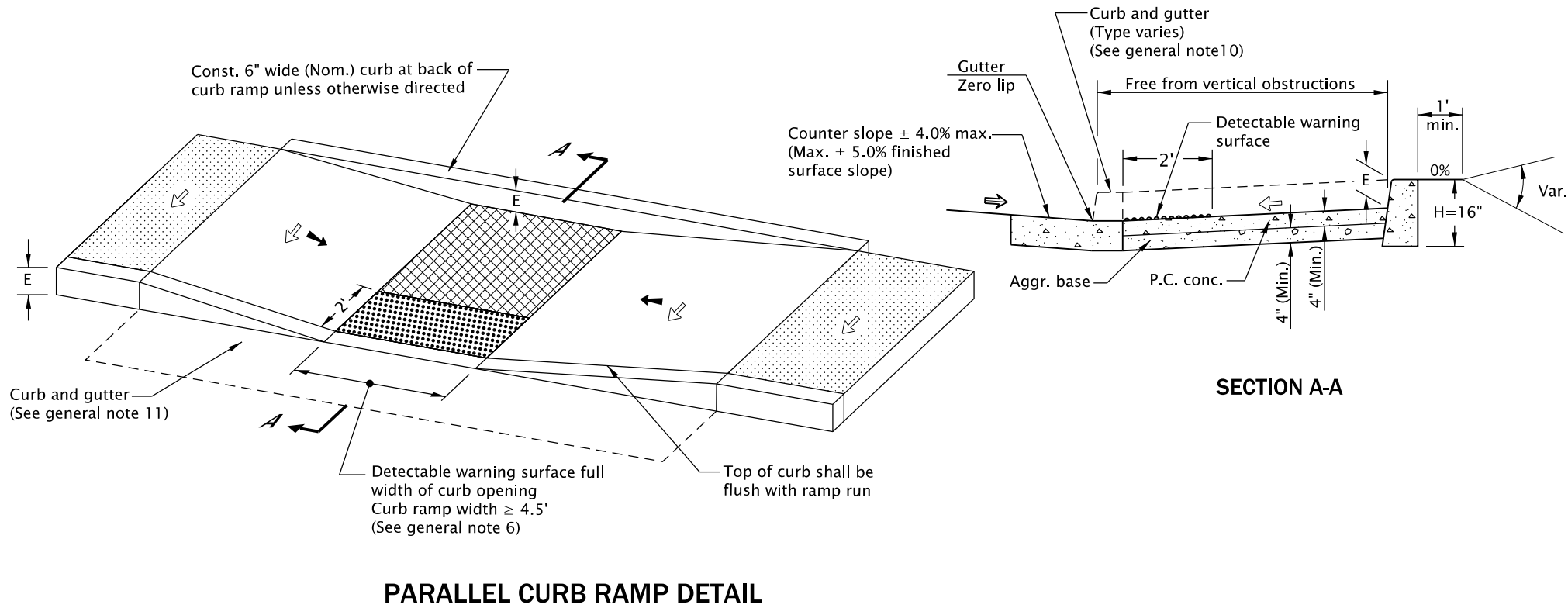

GENERAL NOTES FOR ALL DETAILS ON THIS SHEET:

1. Curb ramp details are based on applicable ODOT Standards.
2. See Std. Dwgs. RD700 & RD701 for curbs. See Std. Dwgs. RD720 & RD721 for sidewalks. See Std. Dwgs. RD902 through RD908 for detectable warning surface installation details. See Std. Dwg. TM240 for crosswalk closure detail.
3. Site conditions normally require a project specific design. See project plans for details not shown.
4. Tooled dummy joints are required at all curb ramp grade break lines, (see Std. Dwg. RD722).
5. Curb ramp slopes shown are relative to the true level horizon (zero bubble).
6. Place detectable warning surface at the back of curb for a minimum depth of 2' in the direction of pedestrian travel full width of curb ramp opening that is adjacent to traffic.
7. Grade breaks at the top and bottom of curb ramp runs shall be perpendicular to the direction of the ramp run. Grade breaks shall not be permitted on the surface of ramp runs and turning spaces. Surface slopes that meet at grade breaks shall be flush.
8. When 2 ramp runs are immediately adjacent, the curb exposure (E) between the adjacent side may range between 3" and full design exposure.
9. Curb ramps for shared use paths intersecting a roadway shall be full width of path, excluding flares. When a curb ramp is used to provide bicycle access from a roadway to a sidewalk, the curb ramp opening will be $\geq 8'$ wide, (see Std. Dwg. RD909 for additional details).
10. Place an inlet at upstream side of curb ramp or perform other approved design mitigation. Check the gutter flow depth at curb ramp locations to assure that the design flood does not overtop the back of sidewalk.
11. On or along state highways, curb and gutter is required at curb ramps.

LEGEND:

- Sidewalk
- Detectable warning surface
- Level area (Turning space/landing)
Unobstructed 4.5' x 4.5'
With obstruction 4.5' x 5.5' (Longer dimension in direction of pedestrian street crossing).
For the purposes of this application, a max. 2.0% finished surface slope (for drainage) measured perpendicular in two directions is considered level.
- Cross slope 1.5% max.
(Max. 2.0% finished surface slope)
(Normal sidewalk cross slope)
- Running slope 7.5% max.
(Max. 8.3% finished surface slope)
- Counter slope 4.0% max. ascending or descending,
(Max. 5.0% finished surface slope)
Slope as required for drainage
- 4'x4' clear space

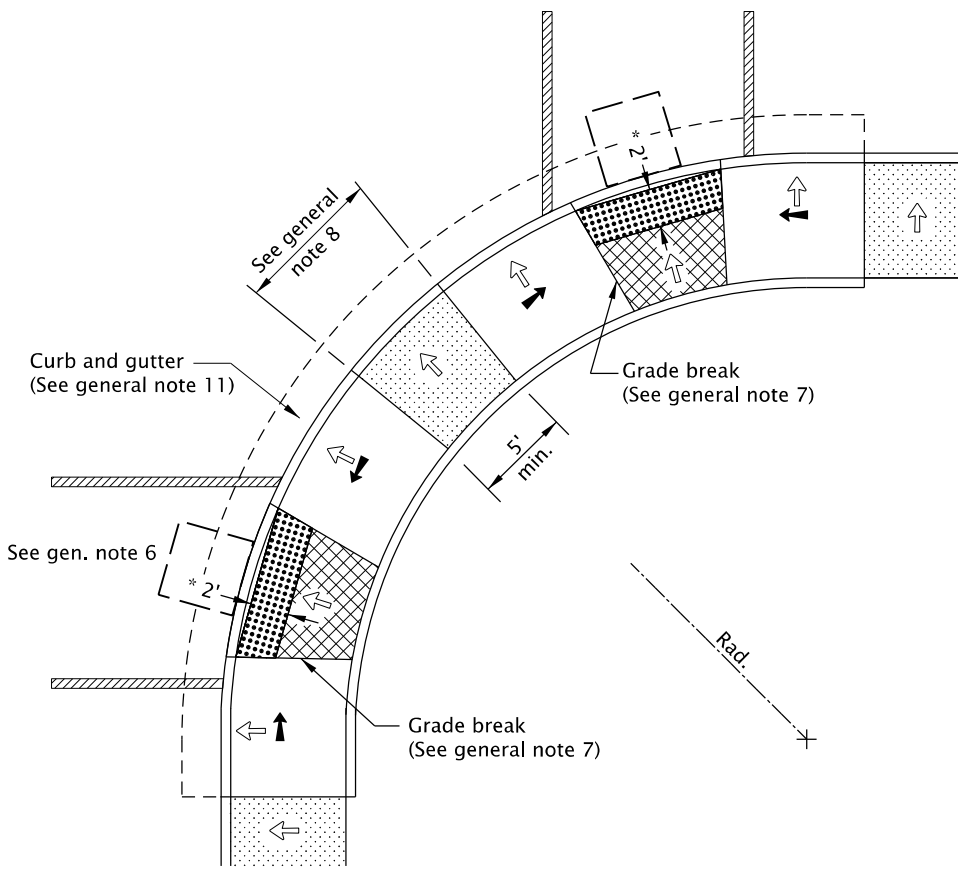

PARALLEL CURB RAMPS
OPTION "PL-1"

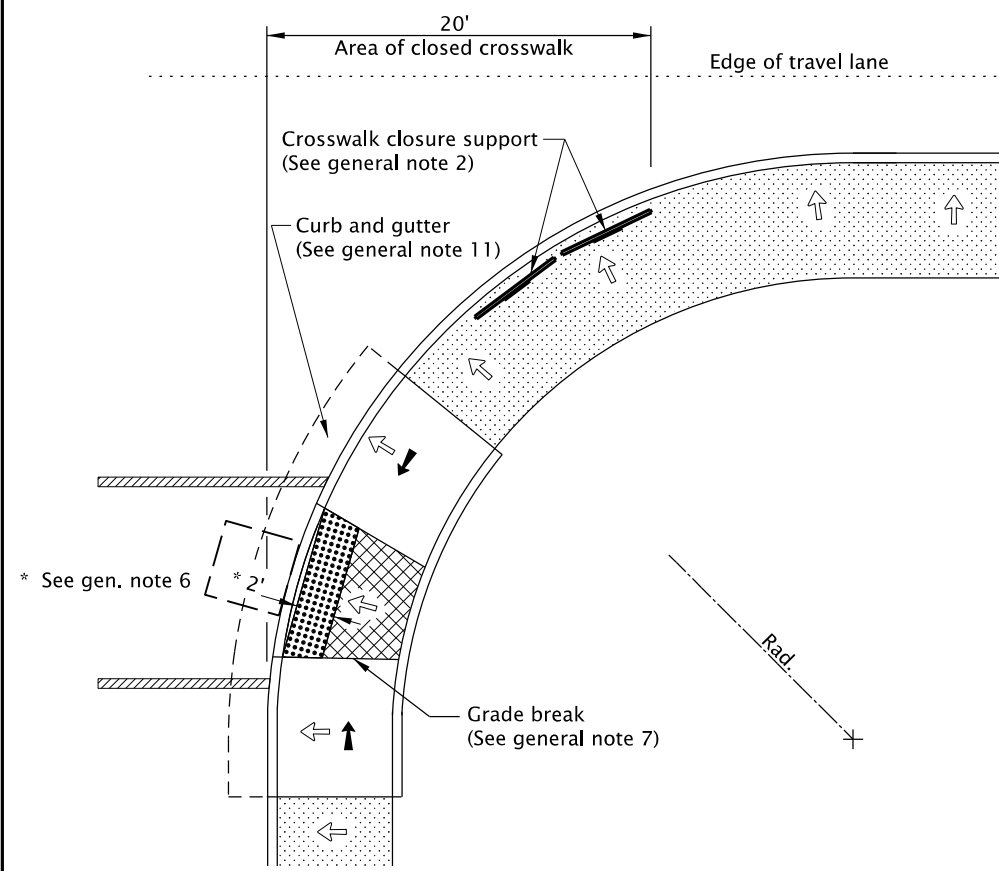

PARALLEL CURB RAMP WITH CROSSWALK CLOSURE
OPTION "PL-2"

The selection and use of this Standard Drawing, while designed in accordance with generally accepted engineering principles and practices, is the sole responsibility of the user and should not be used without first consulting a Registered Professional Engineer.

All materials shall be in accordance with the current Oregon Standard Specifications.

OREGON STANDARD DRAWINGS

PARALLEL CURB RAMP

2024

DATE	REVISION	DESCRIPTION
07-2020	NEW DRAWING CREATED	
07-2021	REVISED DETAIL AND NOTES	
01-2022	REVISED NOTES	

CALC. BOOK NO. ---	N/A ---	SDR DATE: 14-JAN-2022	RD920
--------------------	---------	-----------------------	-------

Effective Date: December 1, 2023 – May 31, 2024









14-JAN-2022

RD930.dgn

GENERAL NOTES FOR ALL DETAILS ON THIS SHEET:

1. Curb ramp details are based on applicable ODOT Standards.
2. See project plans for details not shown.
See Std. Dwgs. RD700 & RD701 for curbs.
See Std. Dwgs. RD720 & RD721 for sidewalks.
See Std. Dwgs. RD902 through RD908 for detectable warning surface installation details.
3. Site conditions normally require a project specific design. See project plans for details not shown.
4. Tooled dummy joints are required at all curb ramp slope break lines, (see Std. Dwg. RD722).
5. Curb ramp slopes shown are relative to the true level horizon (zero bubble).
6. Place detectable warning surface at the back of curb for a minimum depth of 2' in the direction of pedestrian travel full width of curb ramp opening that is adjacent to traffic.
7. Place an inlet at upstream side of curb ramp or perform other approved design mitigation. Check the gutter flow depth at curb ramp locations to assure that the design flood does not overtop the back of sidewalk.
8. Return curb may be provided in lieu of flared slope only if protected from traverse travel by landscaping, see Std. Dwg. RD721. Return curb shall not reduce width of approaching sidewalk.
9. Curb ramps for shared use paths intersecting a roadway shall be full width of path, excluding flares. When a curb ramp is used to provide bicycle access from a roadway to a sidewalk, the curb ramp opening will be $\geq 8'$ wide, (see Std. Dwg. RD909 for additional details).
10. On or along state highways, curb and gutter is required at curb ramps.
11. Grade breaks at the top and bottom of curb ramp runs shall be perpendicular to the direction of the ramp run. Grade breaks shall not be permitted on the surface of ramp runs and turning spaces. Surface slopes that meet at grade breaks shall be flush.

LEGEND:

-  Marked or intended crossing location
-  Sidewalk
-  Detectable warning surface
-  Level area (Turning space/landing)
Unobstructed 4.5' x 4.5'
With obstruction 4.5' x 5.5' (Longer dimension in direction of pedestrian street crossing).
For the purposes of this application, a max. 2.0% finished surface slope (for drainage) measured perpendicular in two directions is considered level.
-  Cross slope 1.5% max.
(Max. 2.0% finished surface slope)
(Normal sidewalk cross slope)
-  Running slope 7.5% max.
(Max. 8.3% finished surface slope)
-  Counter slope 4.0% max. ascending or descending,
(Max. 5.0% finished surface slope)
Slope as required for drainage
-  Flare slope
(Max. 10% finished surface slope)

The selection and use of this Standard Drawing, while designed in accordance with generally accepted engineering principles and practices, is the sole responsibility of the user and should not be used without first consulting a Registered Professional Engineer.

All materials shall be in accordance with the current Oregon Standard Specifications.		
OREGON STANDARD DRAWINGS		
COMBINATION CURB RAMP		
2024		
DATE	REVISION	DESCRIPTION
07-2020	NEW DRAWING CREATED	
07-2021	REVISED DETAIL AND NOTES	
01-2022	REVISED NOTES	
CALC. BOOK NO.	N/A	SDR DATE
		14-JAN-2022
		RD930

Effective Date: December 1, 2023 – May 31, 2024

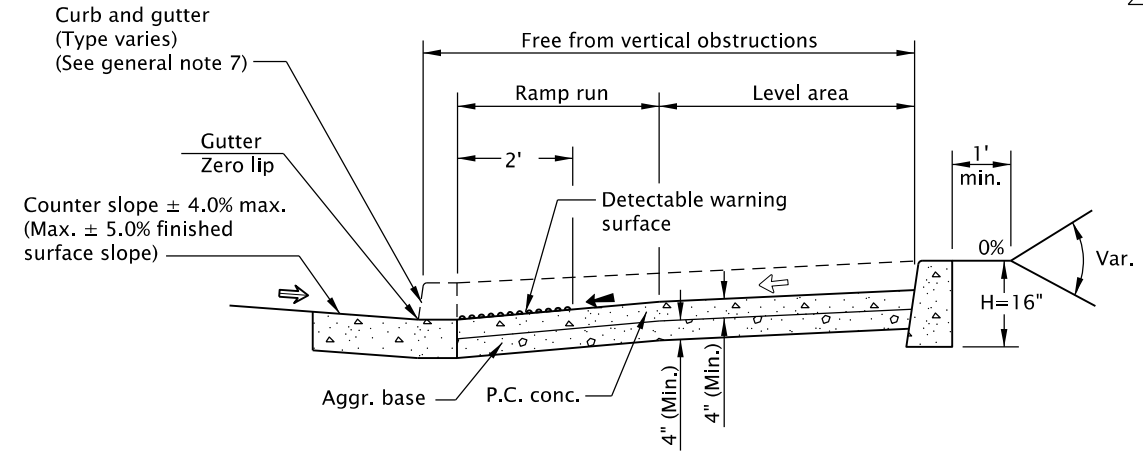
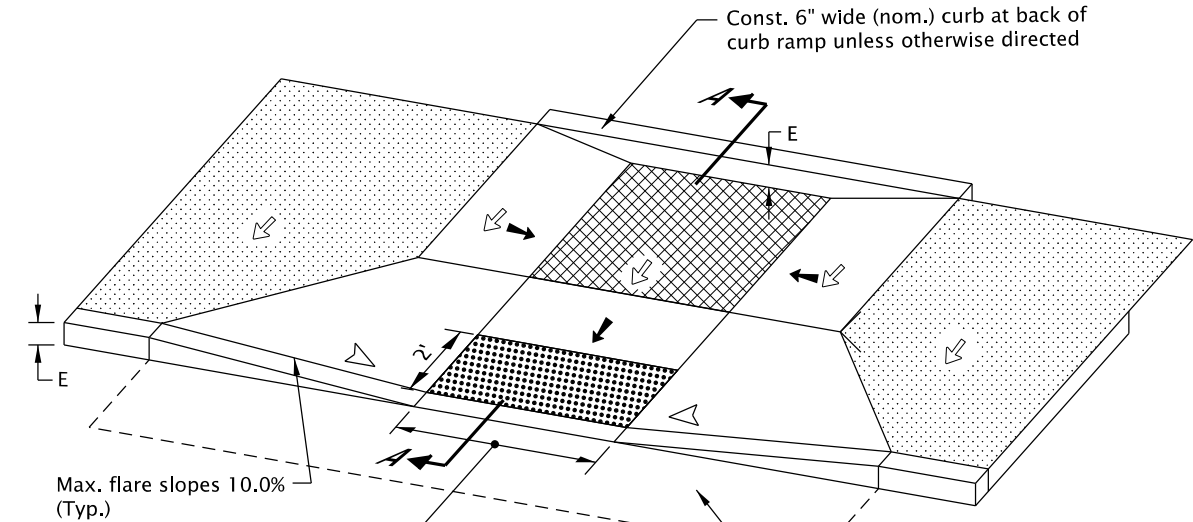

SECTION A-A

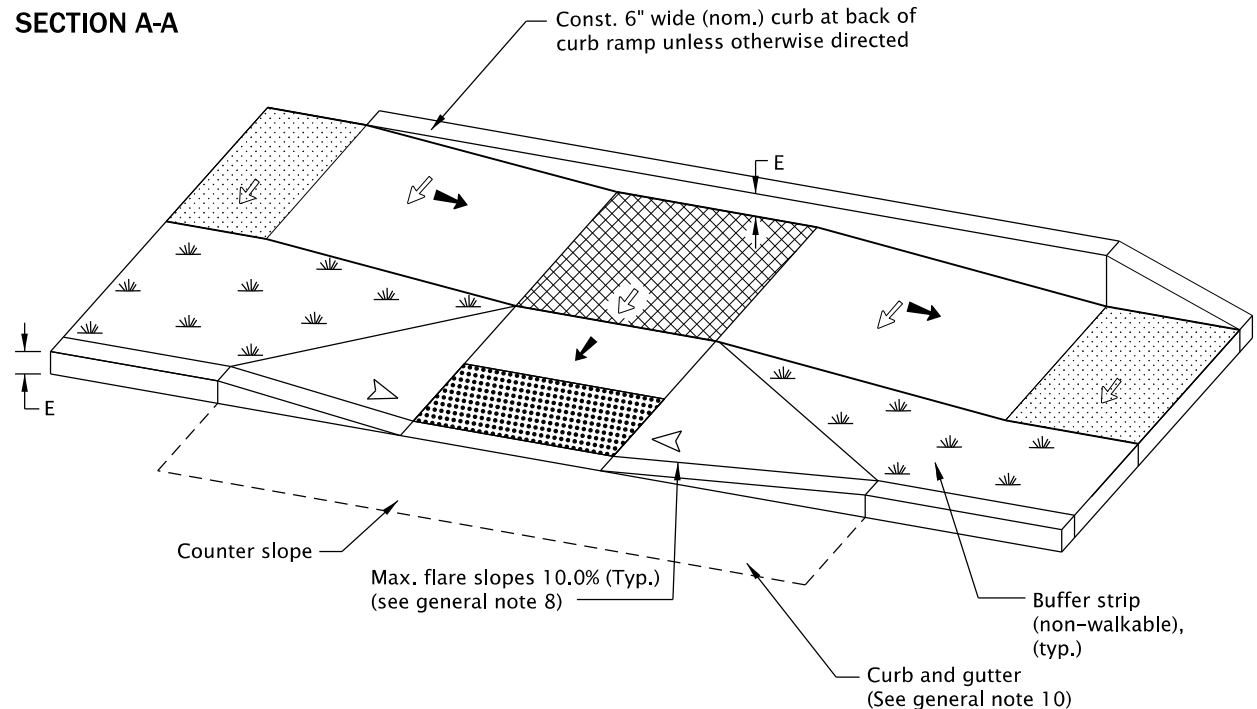

COMBINATION CURB RAMP DETAIL

19-JUL-2021



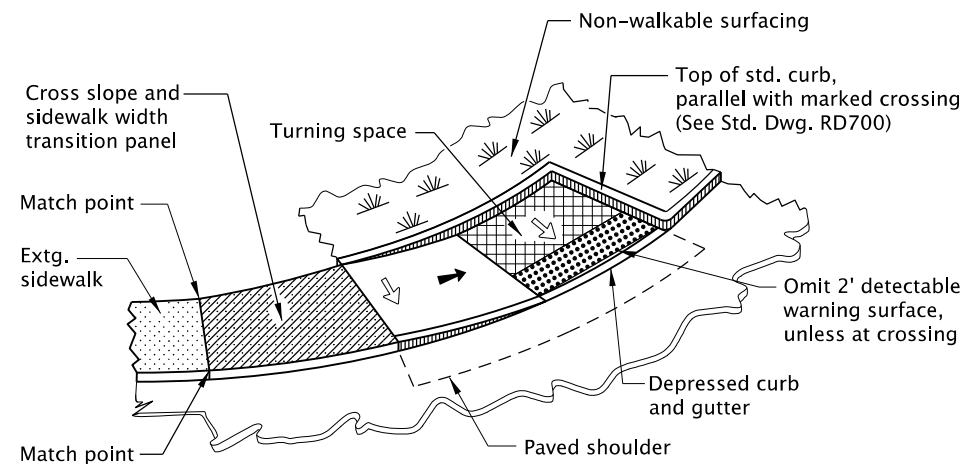
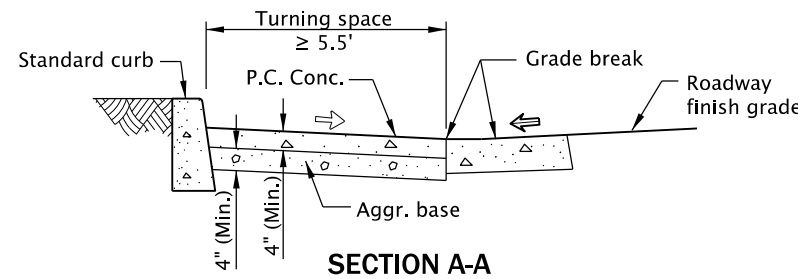
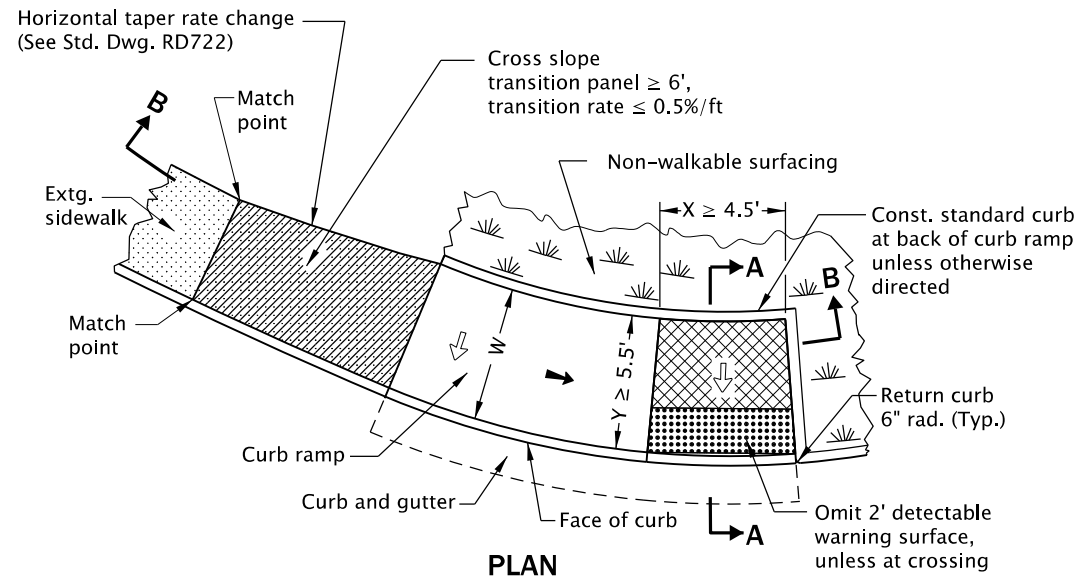
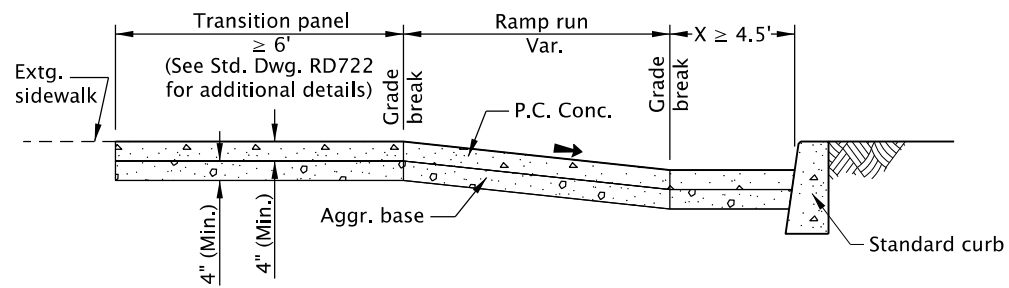





RD960.dgn



GENERAL NOTES FOR ALL DETAILS ON THIS SHEET:

1. Curb ramp details are based on applicable ODOT applicable Standards.
2. See project plans for details not shown. See Std. Dwgs. RD700 & RD701 for curbs. See Std. Dwgs. RD720 & RD721 for sidewalks. See Std. Dwg. RD722 for transition panel details. See Std. Dwgs. RD902 through RD908 for detectable warning surface installation details. See Std. Dwg. RD920 for parallel curb ramp details.
3. Site conditions normally require a project special design. See project plans for details not shown.
4. Tooled dummy joints are required at all curb ramp grade break lines, (see Std. Dwg. RD722).
5. Curb ramp slopes shown are relative to the true level horizon (zero bubble).
6. Place detectable warning surface at the back of curb for a minimum depth of 2' in the direction of pedestrian travel full width of curb ramp opening that is adjacent to traffic.
7. Place an inlet at upstream side of curb ramp or perform other approved design mitigation. Check the gutter flow depth at curb ramp locations to assure that the design flood does not overtop the back of sidewalk.
8. When a shared use path terminates, the curb ramp shall be the full width of the path, the turning space Y-dimension should be minimum 8' wide to enable bicycles to ride from ramp to shoulder.
9. Grade breaks at the top and bottom of curb ramp runs shall be perpendicular to the direction of the ramp run. Grade breaks shall not be permitted on the surface of ramp runs and turning spaces. Surface slopes that meet at grade breaks shall be flush.
10. On or along state highways, curb and gutter is required at curb ramps.
11. Unique curb ramp option can be used for curved or tangent roadway sections. Superelevated roadways require a site specific detail.

LEGEND:

-  Sidewalk
-  Transition panel
-  Detectable warning surface
-  Level area (Turning space/landing)
Unobstructed 4.5' x 4.5'
With obstruction 4.5' x 5.5' (Longer dimension in direction of pedestrian street crossing).
For the purposes of this application, a max. 2.0% finished surface slope (for drainage) measured perpendicular in two directions is considered level.
-  Cross slope 1.5% max.
(Max. 2.0% finished surface slope)
(Normal sidewalk cross slope)
-  Running slope 7.5% max.
(Max. 8.3% finished surface slope)
-  Counter slope 4.0% max. ascending or descending,
(Max. 5.0% finished surface slope)
Slope as required for drainage
-  W New construction sidewalk width. See contract plans for dimension

The selection and use of this Standard Drawing, while designed in accordance with generally accepted engineering principles and practices, is the sole responsibility of the user and should not be used without first consulting a Registered Professional Engineer.

All materials shall be in accordance with the current Oregon Standard Specifications.

OREGON STANDARD DRAWINGS

UNIQUE CURB RAMP

2024

DATE	REVISION	DESCRIPTION
07-2020	NEW DRAWING CREATED	
07-2021	REVISED DETAILS AND NOTES	

CALC. BOOK NO.	N/A	SDR DATE	19-JUL-2021	RD960
----------------	-----	----------	-------------	-------

Effective Date: December 1, 2023 – May 31, 2024

RD1010.dgn 20-JAN-2021

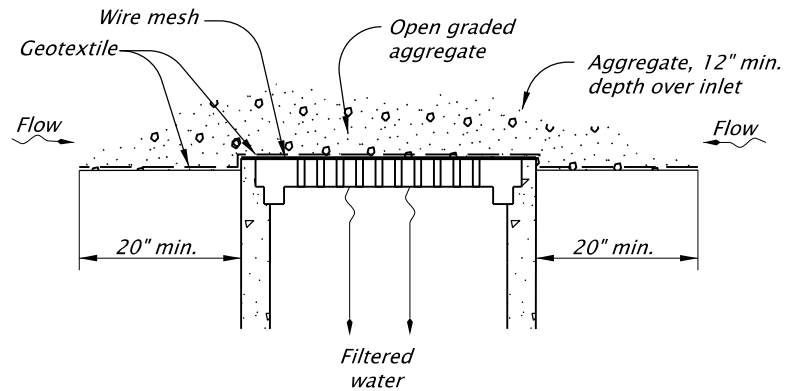

GEOTEXTILE/WIRE MESH/AGGREGATE - TYPE 2
NOT TO SCALE

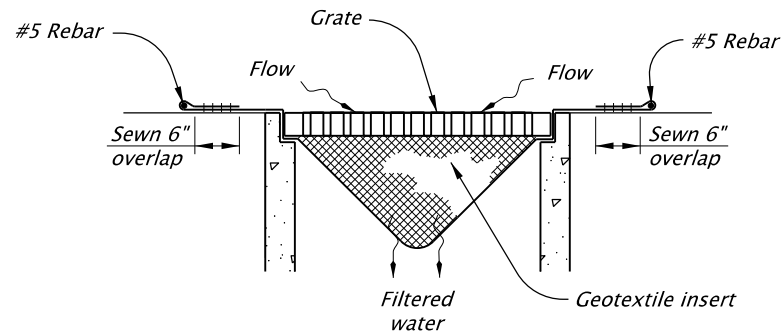

PREFABRICATED FILTER INSERT - TYPE 3
NOT TO SCALE

NOTE:
Install sod around the perimeter of inlets within 36 hours of harvest of the sod

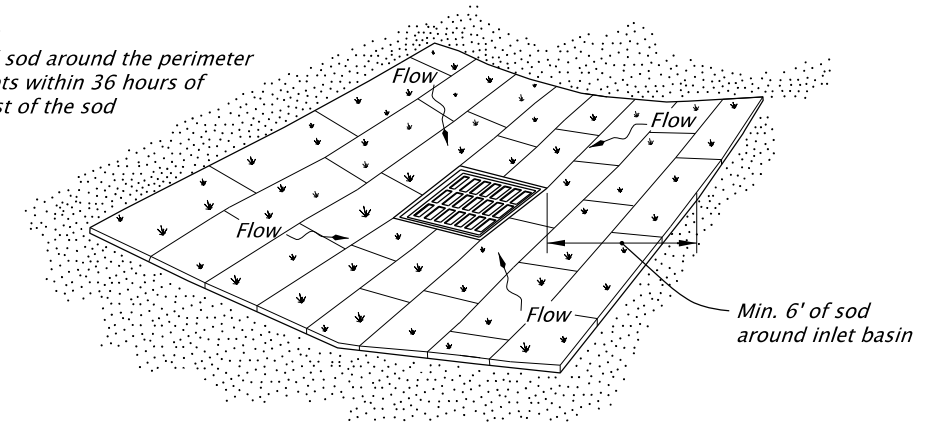

SOD PROTECTION - TYPE 6
NOT TO SCALE

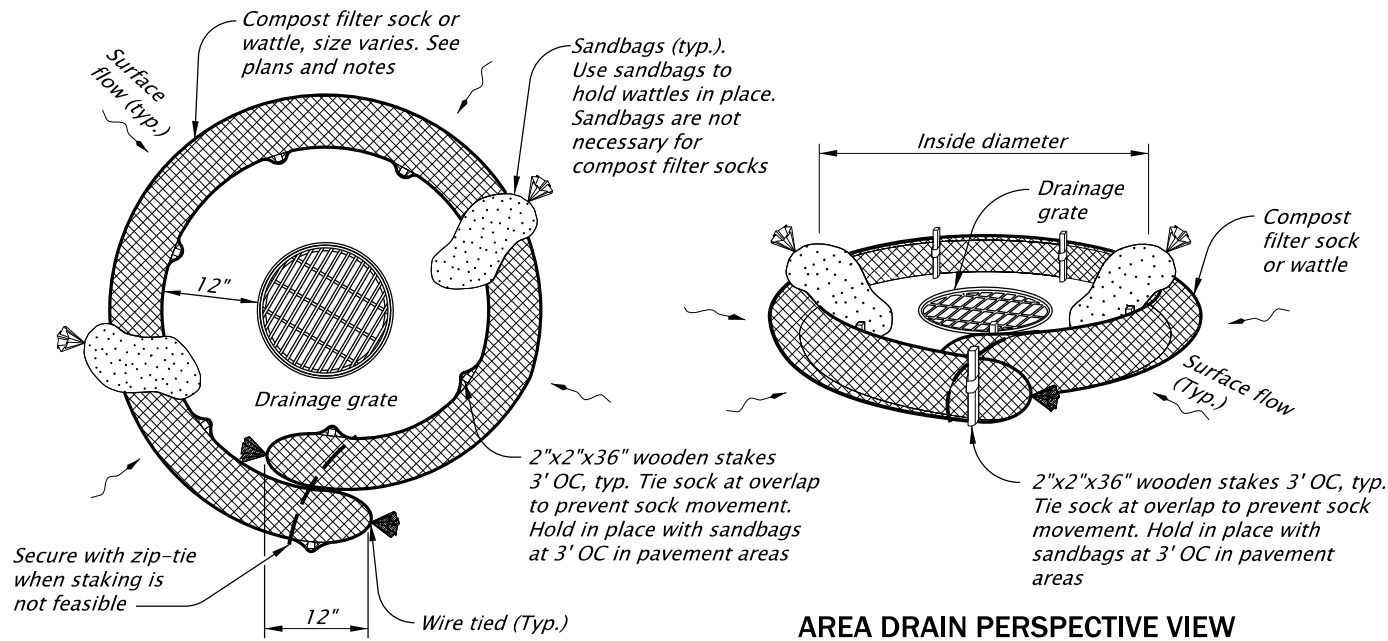

AREA DRAIN PERSPECTIVE VIEW

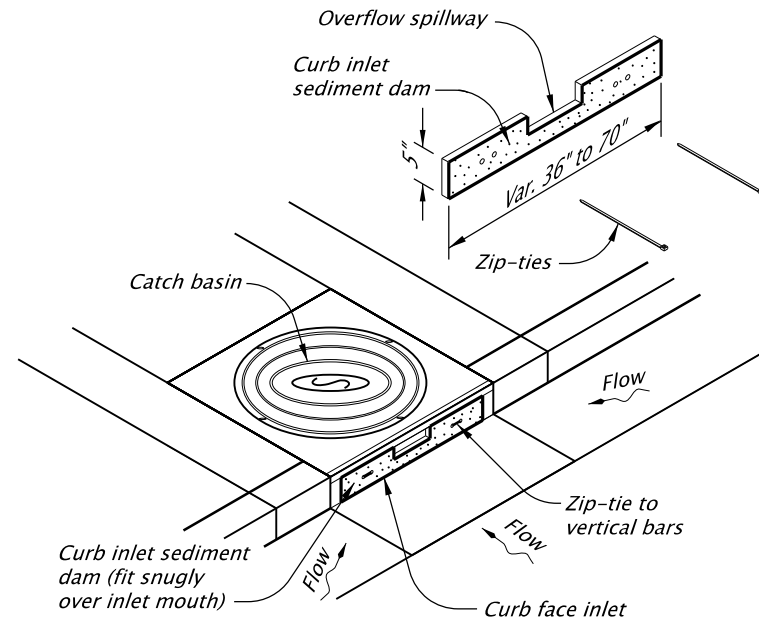

CURB INLET SEDIMENT DAM - TYPE 10
NOT TO SCALE

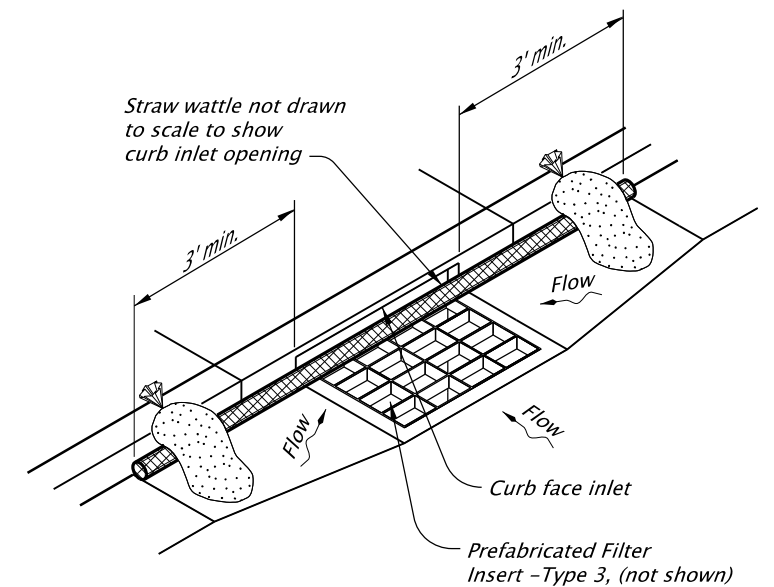

WATTLE BARRIER WITH FILTER INSERT - TYPE 11
NOT TO SCALE

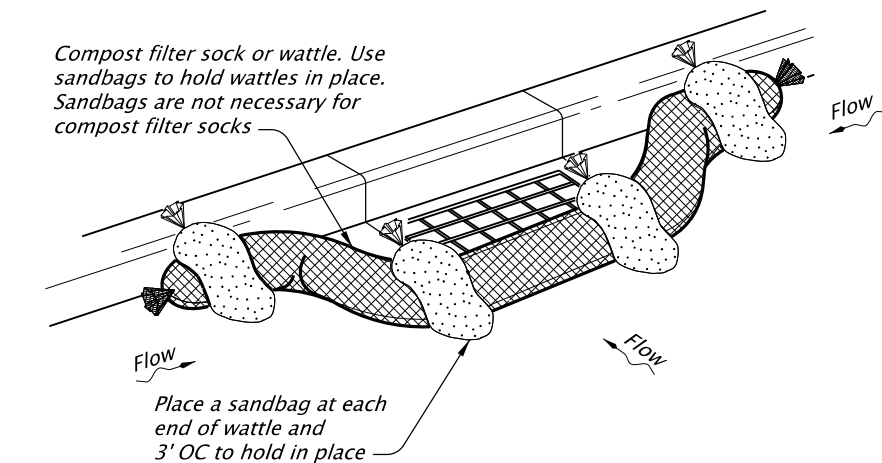

COMPOST FILTER SOCK OR WATTLE - TYPE 7
NOT TO SCALE

NOTES:
Type 2 - Geotextile/wire mesh/aggregate
Place the wire mesh over the grate.
Place sediment fence geotextile over the wire mesh and perimeter area around structure.
Install aggregate over the geotextile fabric.

Type 3 - Prefabricated filter inserts
Install prefabricated filter inserts according to the plans, special provisions, and manufacturer recommendations.
Prefabricated inserts with provisions for overflow are allowed only when accompanied by additional BMP's to prevent the potential of sediments entering project storm systems.
Field fabricated inserts are not allowed.

Type 7 - Compost filter sock
Drive 2"x2" wood stakes a minimum of 6" into ground and flush with the top of the sock.
Overlap ends of sock per manufacturers recommendations (12" min., 36" max.).
Use 8" to 12" dia sock on curbside in traffic areas.

(Type 7 cont.)
Use 12" to 18" dia sock in non-traffic areas or areas where the larger socks can be used safely.
use synthetic mesh socks for temporary installations.

Type 10 - Curb inlet sediment dam
Fit curb inlet sediment dam snugly into inlet mouth. Curb inlet sediment dam is required for use with inlet filter insert where at-grade inlet grate and curb inlet are combined at a catch basin.

Type 11 - Wattle barrier with filter insert
Install prefabricated filter insert per Type 3 detail.
Install wattles over opening and 36" to each side of opening tight against curb. Adjust wattle to force storm water to flow through filter insert or wattle prior to leaving the site.
Adjust, replace or modify the inlet protection as needed to prevent sediment laden water from entering the catch basin.

The selection and use of this Standard Drawing, while designed in accordance with generally accepted engineering principles and practices, is the sole responsibility of the user and should not be used without first consulting a Registered Professional Engineer.

All materials shall be in accordance with the current Oregon Standard Specifications.			
OREGON STANDARD DRAWINGS			
INLET PROTECTION			
TYPE 2, 3, 6, 7, 10 AND 11			
2024			
DATE	REVISION	DESCRIPTION	
01-2021	REMOVED CALC BOOK NUMBERS		
01-2021	MOVED NOTES UP FROM OVERLAPPING THE SHEET BORDER		
CALC. BOOK NO.	N/A	SDR DATE	20-JAN-2021
			RD1010

Effective Date: December 1, 2023 - May 31, 2024

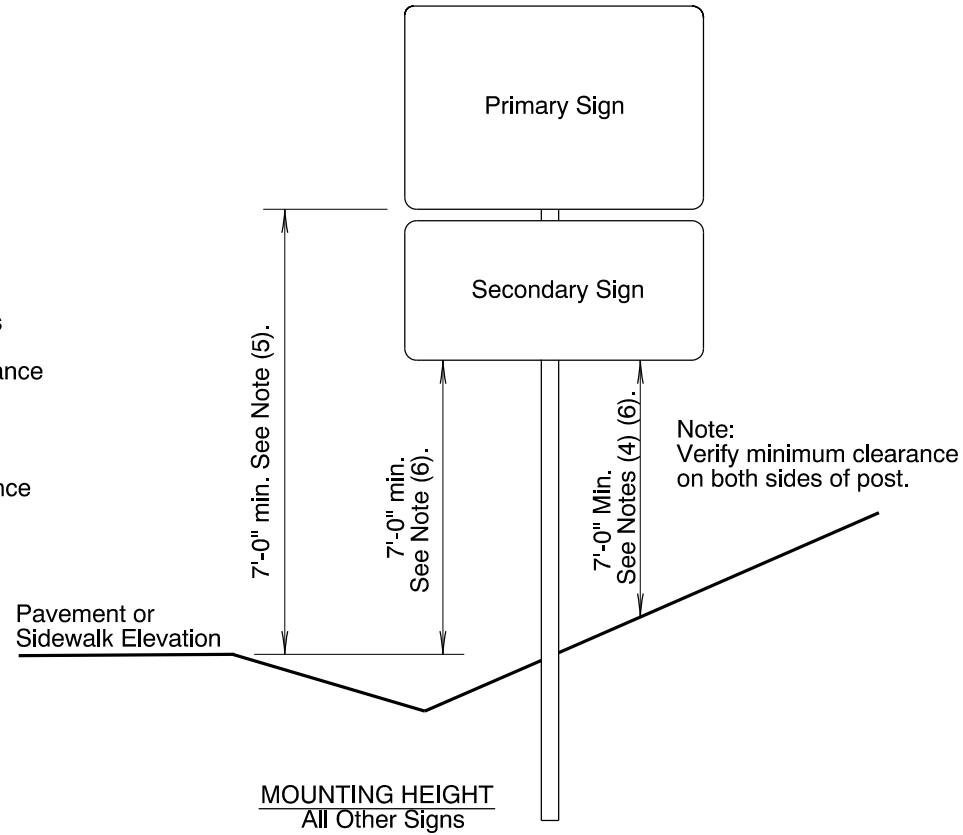
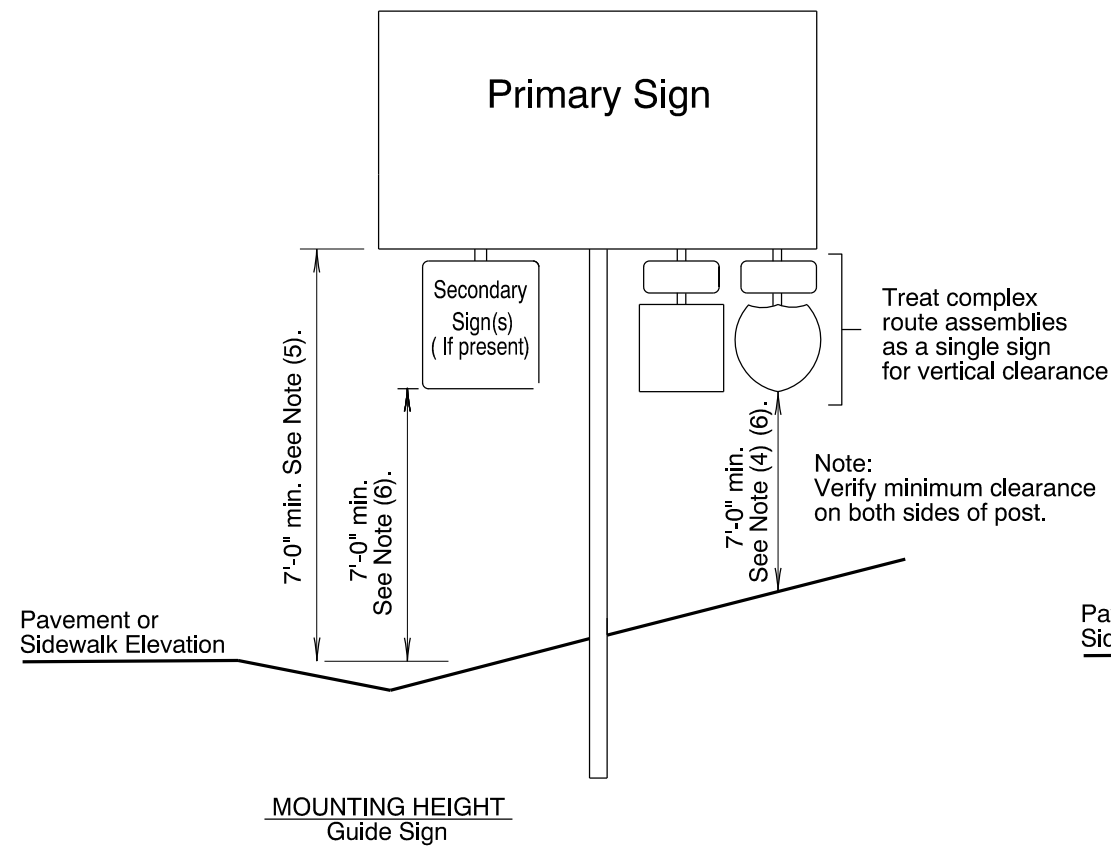

General Installation Notes:

- a. Signing details shown on this sheet are intended to convey "typical" conditions only. Individual locations may require installation different from those shown. For guidance regarding unique installations or exceptions call the Project Sign Designer or Region Traffic Section.
- b. Locate breakaway supports away from ditches to avoid problems with erosion, corrosion, debris, maintenance and breakaway performance. See Dwg. No. TM635 for more information.
- c. For wood post support details see Dwg. No. TM670.
- d. For perforated steelsquare tube support details see Dwg. No. TM681.
- e. For triangular base breakaway support details see Dwg. No. TM602.
- f. For multi-post breakaway support details see Dwg. No. TM600.
- g. Mounting heights should not be more than 3 inches more than the minimum heights shown, where practical.
- h. 2" vertical spacing between all signs.

Notes:

- 1). 6' minimum if behind barrier.
- 2). 2' minimum if restricted R/W.
- 3). 20' for ramp terminals.
- 4). 8' minimum if bicycle path underneath.
- 5). 8' minimum if secondary signs attached.
- 6). 5' minimum if outside clearzone, in rural areas and no pedestrians underneath.
- 7). For multi-post installations measure distance from post closest to roadway.

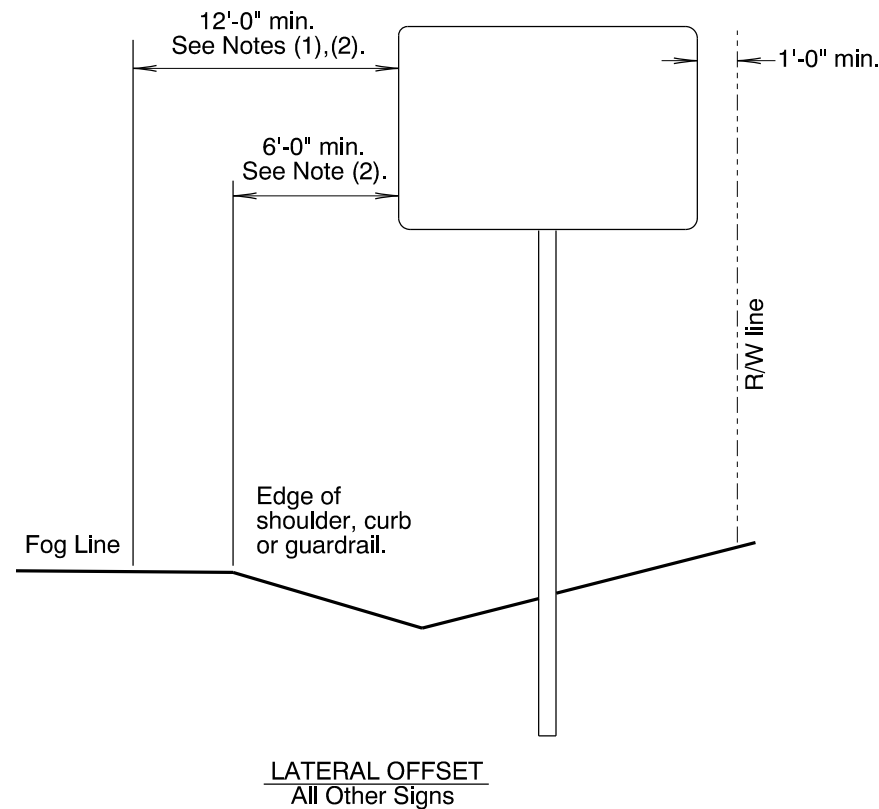
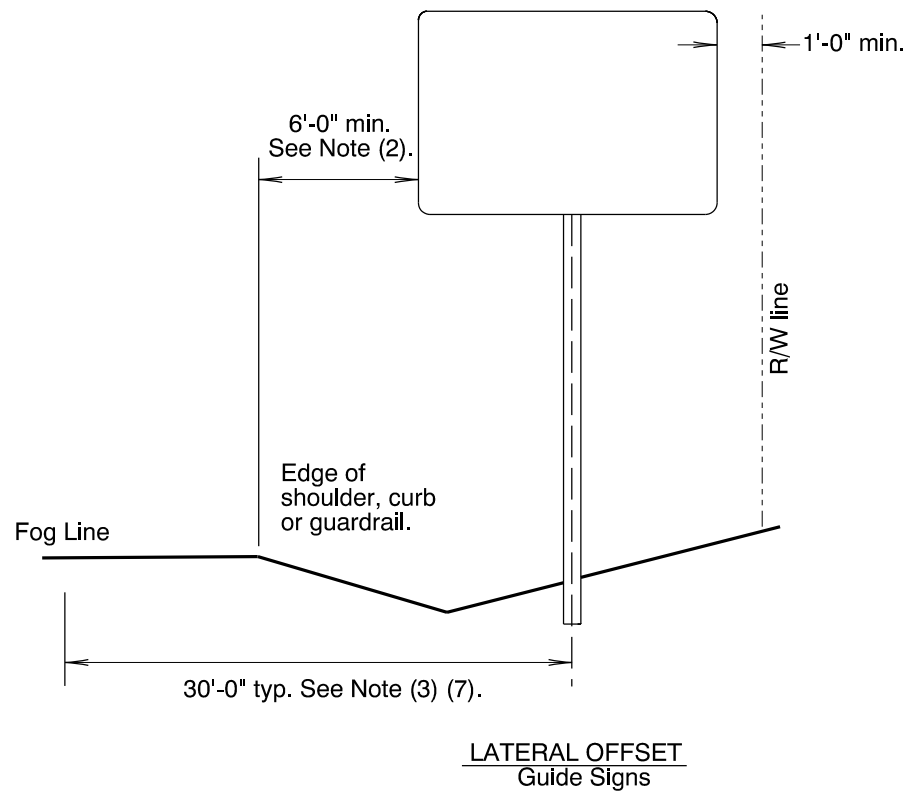

The selection and use of this Standard Drawing, while designed in accordance with generally accepted engineering principles and practices, is the sole responsibility of the user and should not be used without first consulting a Registered Professional Engineer.

All materials shall be in accordance with the current Oregon Standard Specifications.			
OREGON STANDARD DRAWINGS			
SIGN INSTALLATION DETAILS			
2024			
DATE	REVISION	DESCRIPTION	
01/22		Edited elevation text in Mounting Height details	
CALC. BOOK NO.	N/A	SDR DATE	07 JAN 2022
			TM200

filename.dgn DD-MON-YYYY

TM475

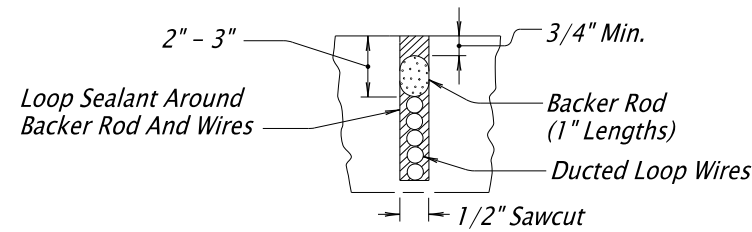

SAWCUT CROSS SECTION
LOOP WIRE INSTALLATION IN EXISTING CONCRETE OR STANDARD ASPHALT MIXES

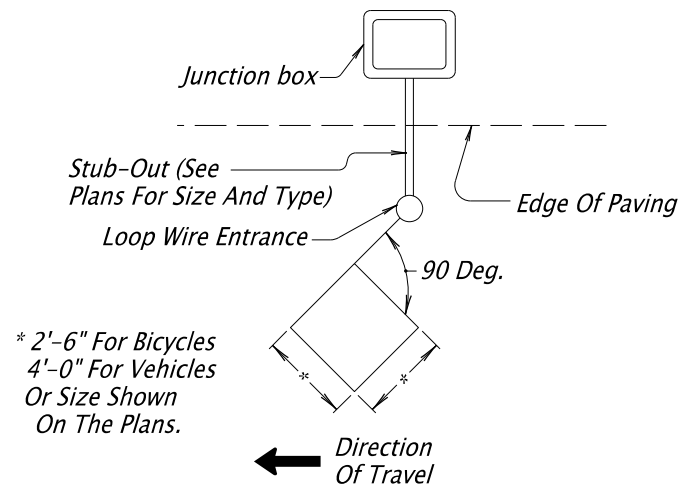

DIAMOND LOOP LAYOUT

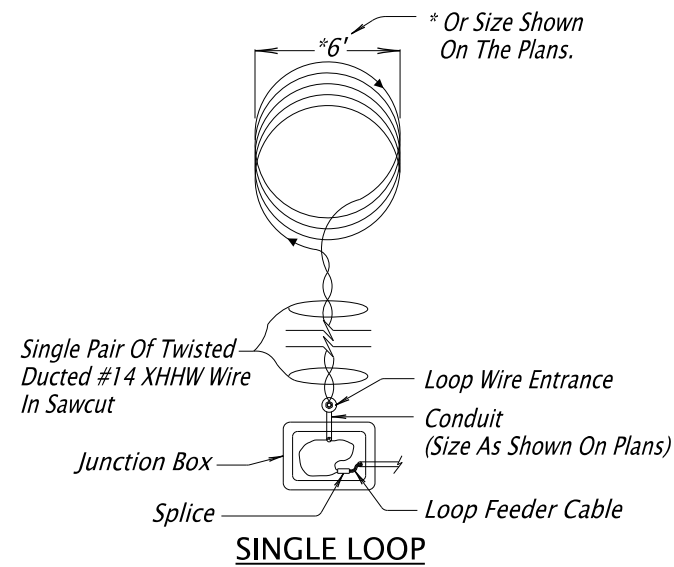
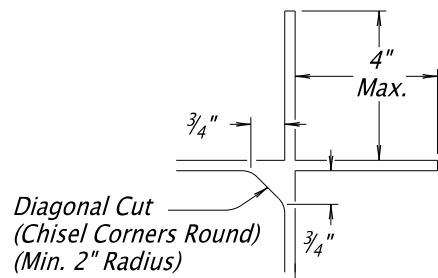

LOOP DETECTOR WINDING PATTERN

(Arrows Indicate Direction Of Loop Winding)

Loops Shall Be Round Or Square With 5 Turns Of Ducted No. 14 XHHW Stranded Wire Centered In The Traffic Lane Or As Shown On Plans. Loop Wire Shall Be Twisted 4 To 6 Turns Per Foot Between Loop And Junction Box. All Loops Shall Be Individually Wired As Shown.

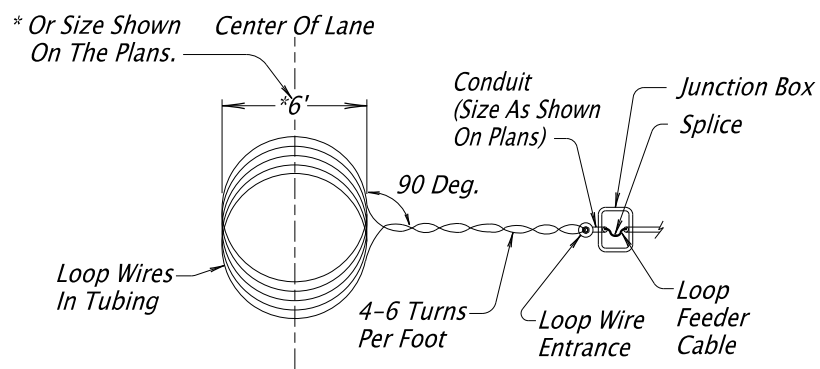

ROUND LOOP LAYOUT

Use Round Loop As Shown On Plans

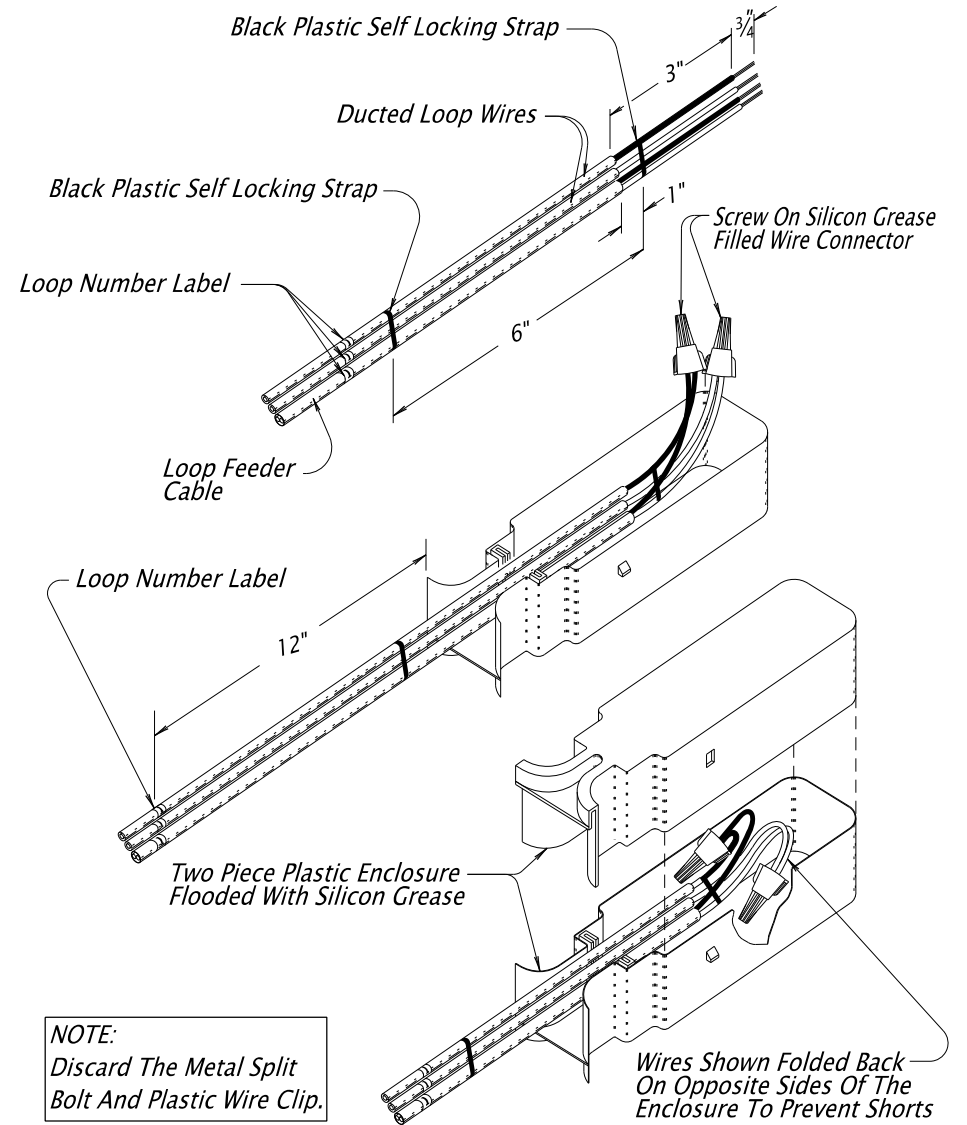

NOTE:
 Discard The Metal Split Bolt And Plastic Wire Clip.

LOOP WIRE TO LOOP FEEDER SPLICES

Mark Loop Number On All Exposed Locations Of Loop Wire And Loop Feeder With Permanent Tags. Use Hand-held Labeler (Brady IDXPRT With XC-1500-580-WT-BK Tags, Or Approved Equal).

At Existing Installations The Contractor Is Responsible For Re-wiring And Re-numbering Of New And Existing Detector Loops And Loop Feeders, In JunctionBoxes And Cabinet, To Match Wiring Diagram.

CALC. BOOK NO. _ N/A _	BASELINE REPORT DATE _ 30-Jun-2017 _
<p>The selection and use of this Standard Drawing, while designed in accordance with generally accepted engineering principles and practices, is the sole responsibility of the user and should not be used without consulting a Registered Professional Engineer.</p>	NOTE: All material and workmanship shall be in accordance with the current Oregon Standard Specifications
	OREGON STANDARD DRAWINGS
	LOOP DETAILS
	2018
DATE	REVISION DESCRIPTION

filename.dgn DD-MON-YYYY

TM480

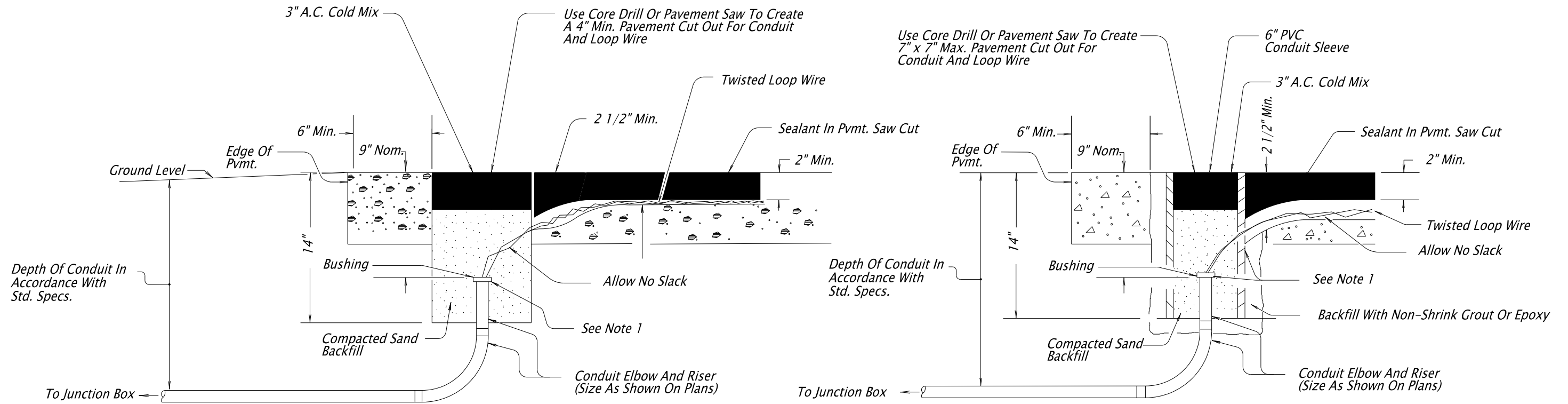

SAND POCKET OPTION

PVC SLEEVE OPTION

LOOP WIRE ENTRANCES

- SAND POCKET OPTION OR P.V.C. SLEEVE INTALLATION NOTES:
- 1.) Install Conduit Plug To Each End Of Conduit Before Installing Sand And A.C.
 - 2.) Elbows And Risers For Conduit Back Into The First Junction Box May Be Any Rigid Non-Metallic Conduit.
 - 3.) Uncurbed Sections As Shown Above.
 - 4.) On Monolithic Curbs, Locate Loop Entrance In Pavement At Edge Of Concrete Gutter.
(Notes 1 And 2 Apply To Curbed And Uncurbed Installations).

CALC. BOOK NO. <u> N/A </u>	BASELINE REPORT DATE <u> 30-Jun-2017 </u>
<p>The selection and use of this Standard Drawing, while designed in accordance with generally accepted engineering principles and practices, is the sole responsibility of the user and should not be used without consulting a Registered Professional Engineer.</p>	NOTE: All material and workmanship shall be in accordance with the current Oregon Standard Specifications
	OREGON STANDARD DRAWINGS
	LOOP ENTRANCE DETAILS
	2018
DATE	REVISION DESCRIPTION

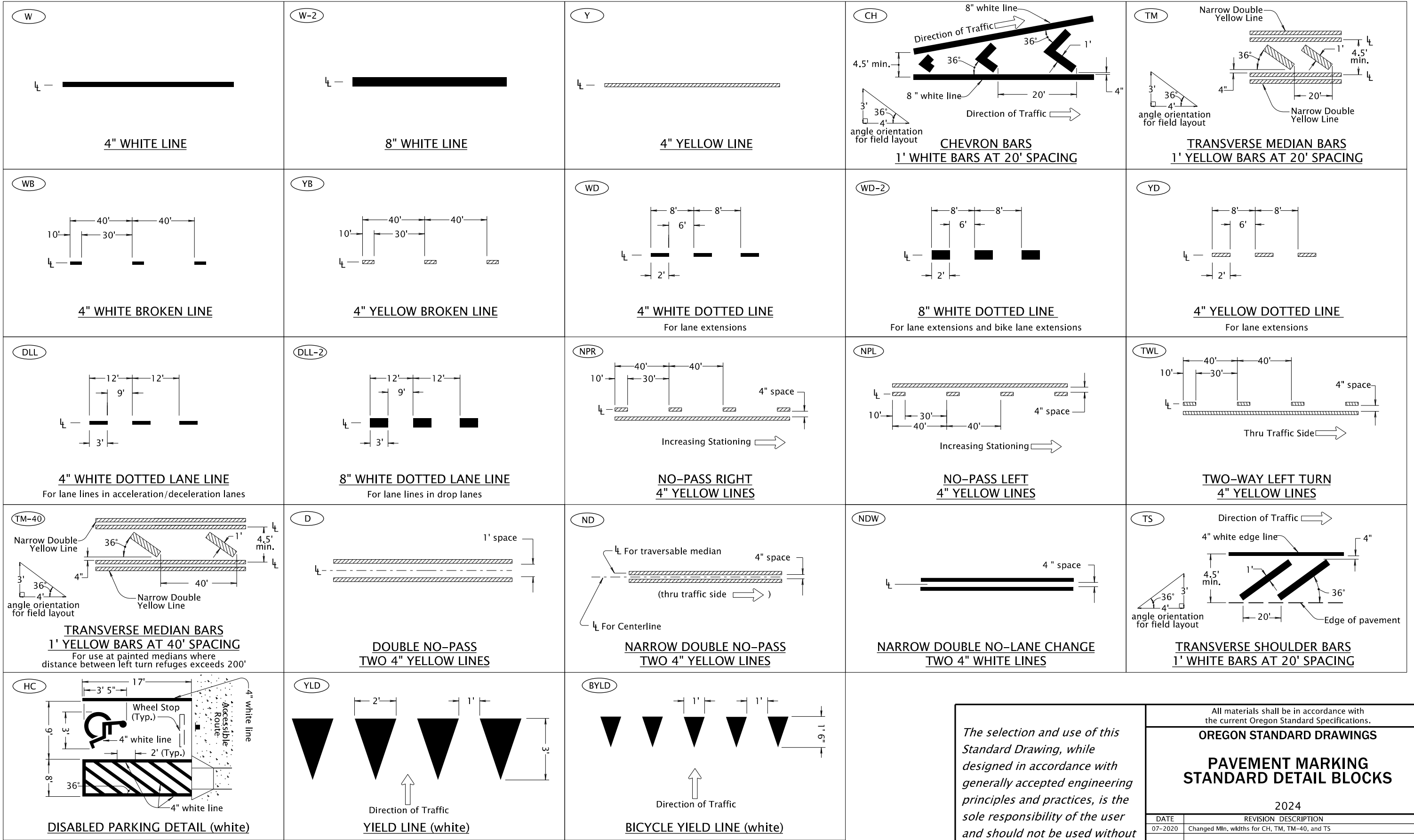

← Direction Of Traffic, Increasing Stationing Or Thru Traffic Side

⊥ Lane line dimensions are shown on the striping plans

LEGEND

The selection and use of this Standard Drawing, while designed in accordance with generally accepted engineering principles and practices, is the sole responsibility of the user and should not be used without first consulting a Registered Professional Engineer.

All materials shall be in accordance with the current Oregon Standard Specifications.	
OREGON STANDARD DRAWINGS	
PAVEMENT MARKING STANDARD DETAIL BLOCKS	
2024	
DATE	REVISION DESCRIPTION
07-2020	Changed Min. widths for CH, TM, TM-40, and TS
CALC. BOOK NO. - - - -	SDR DATE - 07-01-2020 - - - -
N/A	TM500

SA

STRAIGHT ARROW (white)
For arrow proportion details, see current version of Standard Highway Signs

LA

LEFT TURN ARROW (white)
For arrow proportion details, see current version of Standard Highway Signs

RA

RIGHT TURN ARROW (white)
For arrow proportion details, see current version of Standard Highway Signs

LSA

LEFT TURN STRAIGHT ARROW (white)
For arrow proportion details, see current version of Standard Highway Signs

RSA

RIGHT TURN STRAIGHT ARROW (white)
For arrow proportion details, see current version of Standard Highway Signs

RALA

RIGHT TURN LEFT TURN ARROW (white)
For arrow proportion details, see current version of Standard Highway Signs

RSLA

RIGHT TURN STRAIGHT LEFT TURN ARROW (white)
For arrow proportion details, see current version of Standard Highway Signs

E-SA

ELONGATED STRAIGHT ARROW (white)
For arrow proportion details, see current version of Standard Highway Signs

E-LA

ELONGATED LEFT TURN ARROW (white)
For arrow proportion details, see current version of Standard Highway Signs

E-RA

ELONGATED RIGHT TURN ARROW (white)
For arrow proportion details, see current version of Standard Highway Signs

E-LSA

ELONGATED LEFT TURN STRAIGHT ARROW (white)
For arrow proportion details, see current version of Standard Highway Signs

E-RSA

ELONGATED RIGHT TURN STRAIGHT ARROW (white)
For arrow proportion details, see current version of Standard Highway Signs

E-RALA

ELONGATED RIGHT TURN LEFT TURN ARROW (white)
For arrow proportion details, see current version of Standard Highway Signs

E-RSLA

ELONGATED RIGHT TURN STRAIGHT LEFT TURN ARROW (white)
For arrow proportion details, see current version of Standard Highway Signs

F-LA

FISH-HOOK LEFT TURN ARROW (white)
For arrow proportion details, see the current ODOT Traffic Line Manual

F-RALA

FISH-HOOK RIGHT TURN LEFT TURN ARROW (white)
For arrow proportion details, see the current ODOT Traffic Line Manual

F-SA

FISH-HOOK STRAIGHT ARROW (white)
For arrow proportion details, see the current ODOT Traffic Line Manual

F-RSA

FISH-HOOK RIGHT TURN STRAIGHT ARROW (white)
For arrow proportion details, see the current ODOT Traffic Line Manual

F-LSA

FISH-HOOK LEFT TURN STRAIGHT ARROW (white)
For arrow proportion details, see the current ODOT Traffic Line Manual

F-RSLA

FISH-HOOK RIGHT TURN STRAIGHT LEFT TURN ARROW (white)
For arrow proportion details, see the current ODOT Traffic Line Manual

LRA-L

LANE REDUCTION ARROW - LEFT LANE ENDS (white)
For arrow proportion details, see current version of Standard Highway Signs

LRA-R

LANE REDUCTION ARROW - RIGHT LANE ENDS (white)
For arrow proportion details, see current version of Standard Highway Signs

WWA

WRONG-WAY ARROW (white)

General Note:

- Center pavement markings within the lane width.
- Arrow and letter dimensions nominal, excluding WWA.

The selection and use of this Standard Drawing, while designed in accordance with generally accepted engineering principles and practices, is the sole responsibility of the user and should not be used without first consulting a Registered Professional Engineer.

All materials shall be in accordance with the current Oregon Standard Specifications.		
OREGON STANDARD DRAWINGS		
PAVEMENT MARKING STANDARD DETAIL BLOCKS		
2024		
DATE	REVISION	DESCRIPTION
07-2020		Some Detail Blocks moved to new Std. Drawing TM504
01-2022		Fish-hook Arrows added, LRA split into LRA-L and LRA-R
		Corrected bubble callout of LRA-L and typo in LRA-R
CALC. BOOK NO.	N/A	SDR DATE: 01-03-2022
		TM501

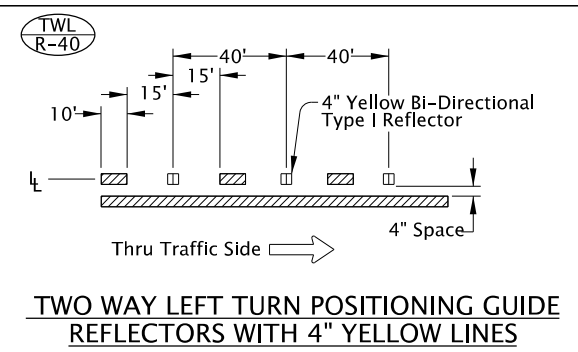
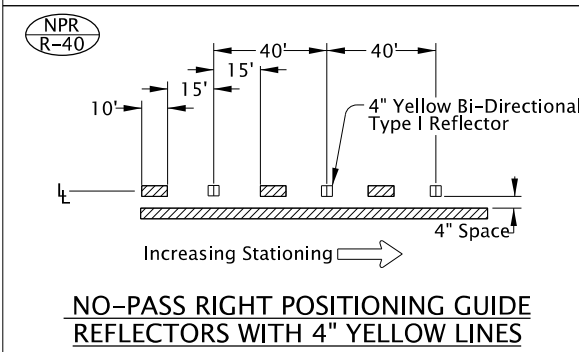
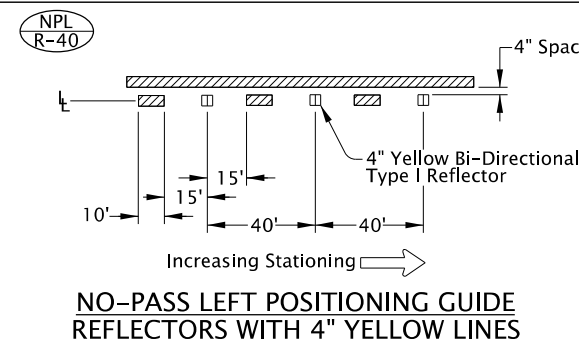
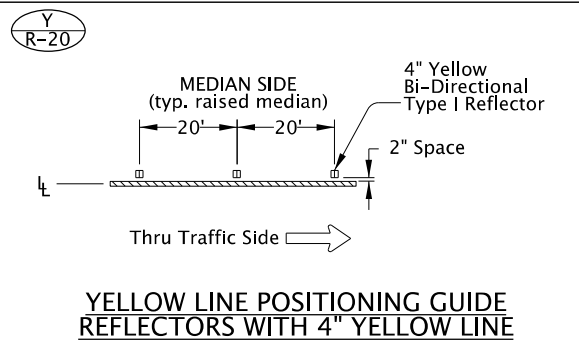
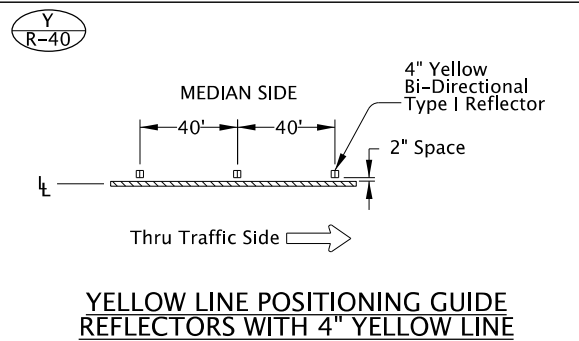
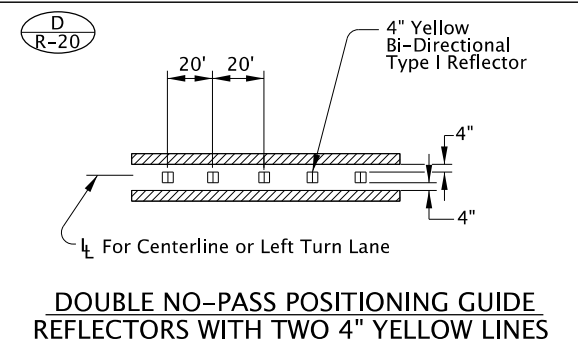
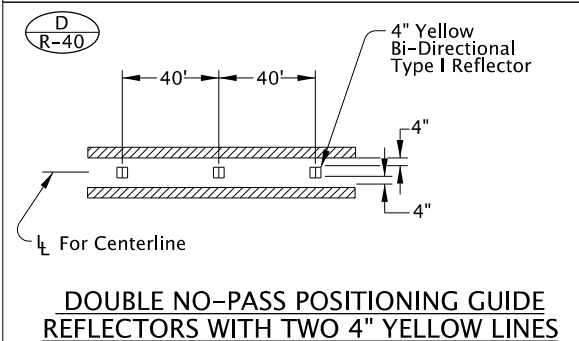
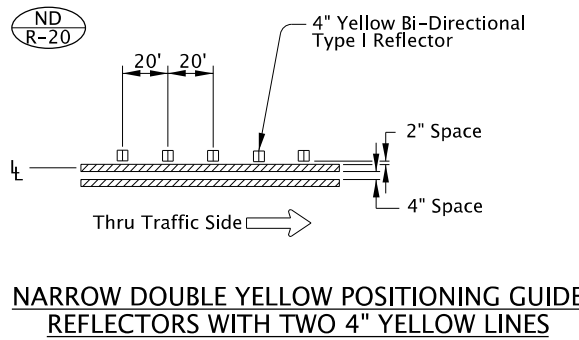
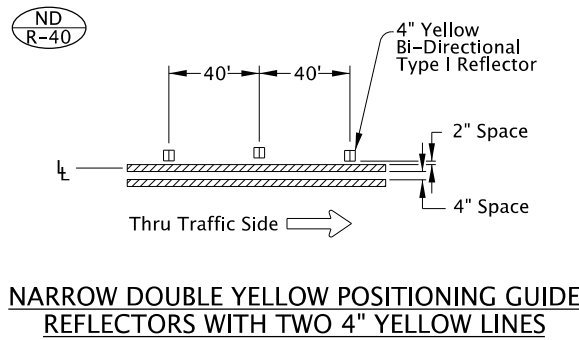
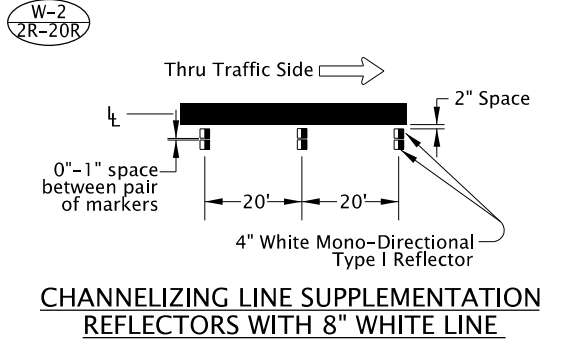
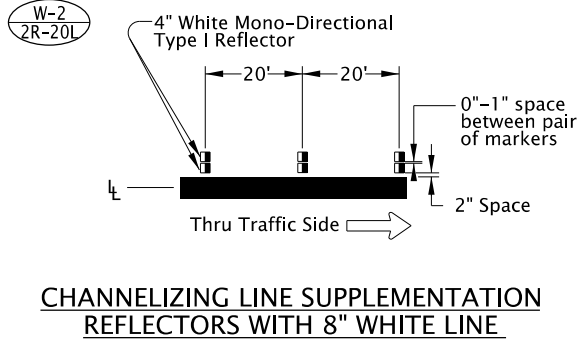
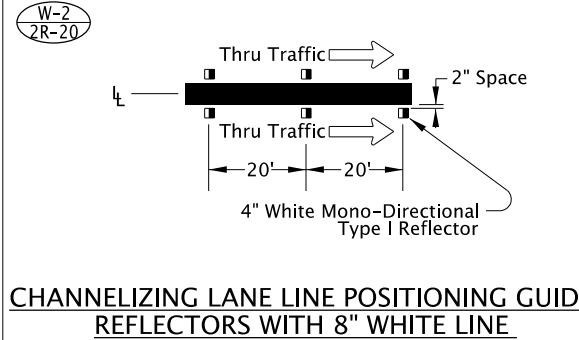
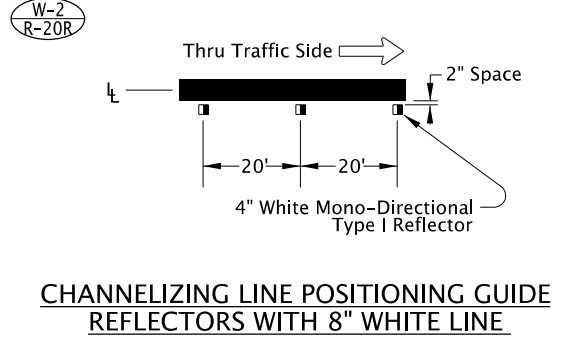
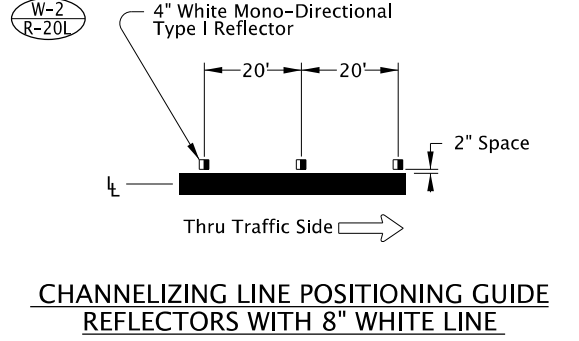
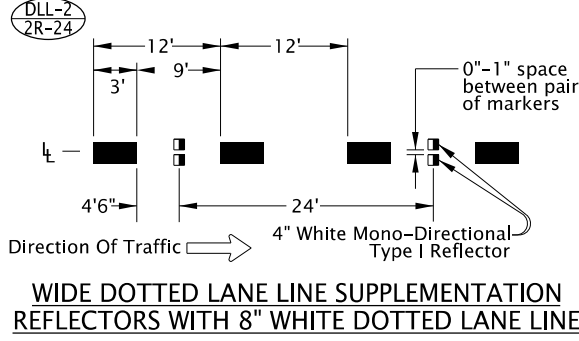
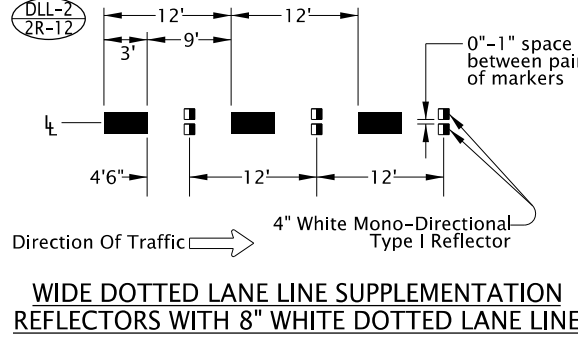
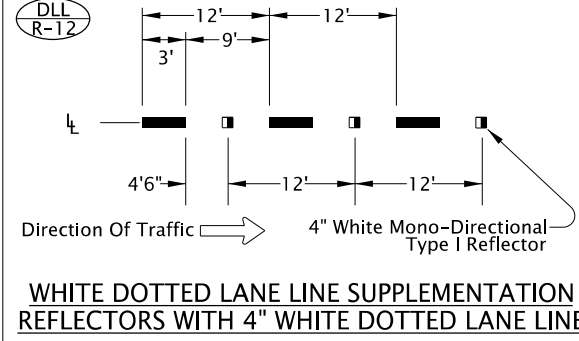
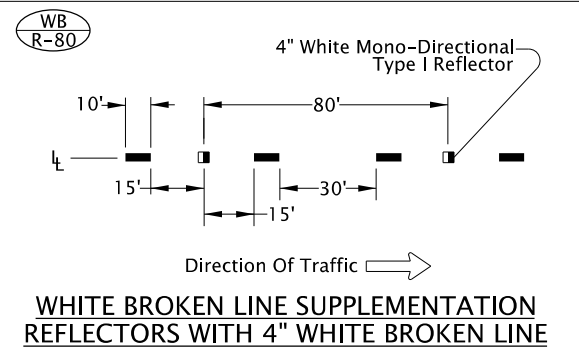
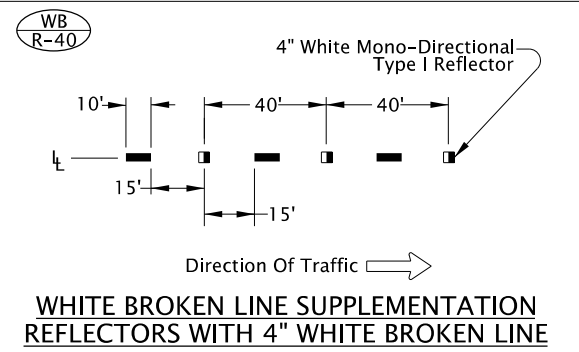
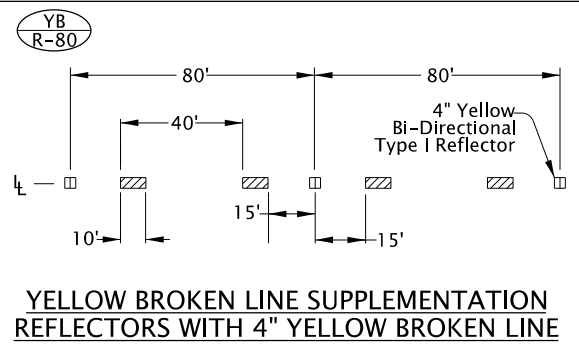
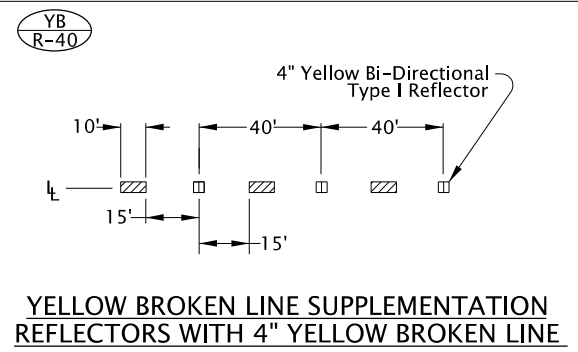
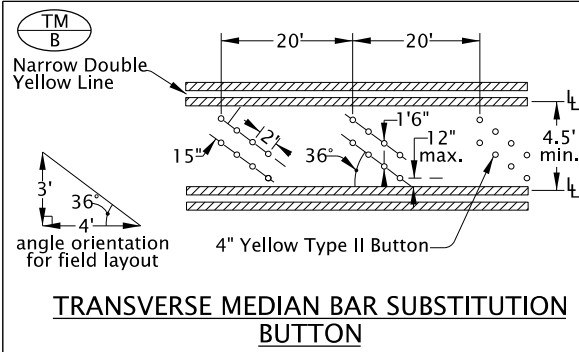

General note:
1) Surface mount Raised Pavement Markers (RPMs) unless otherwise specified.

- LEGEND**
- ← Direction Of Travel, Increasing Stationing or Thru Traffic Side
 - ⊥ Lane line dimensions are shown on the striping plans
 - Mono-directional crystal white marker reflects white to the left in this symbol
 - Bi-directional yellow marker reflects yellow both left and right in this symbol

The selection and use of this Standard Drawing, while designed in accordance with generally accepted engineering principles and practices, is the sole responsibility of the user and should not be used without first consulting a Registered Professional Engineer.

All materials shall be in accordance with the current Oregon Standard Specifications.

OREGON STANDARD DRAWINGS

PAVEMENT MARKING STANDARD DETAIL BLOCKS

2024

DATE	REVISION	DESCRIPTION
07-2020	Changed min. width of TM/B from 6' to 4.5'	
01-2022	Removed "LANE" from W-2/R-20R title	

CALC. BOOK NO. --- N/A ---	SDR DATE: 01-03-2022	TM502
----------------------------	----------------------	--------------

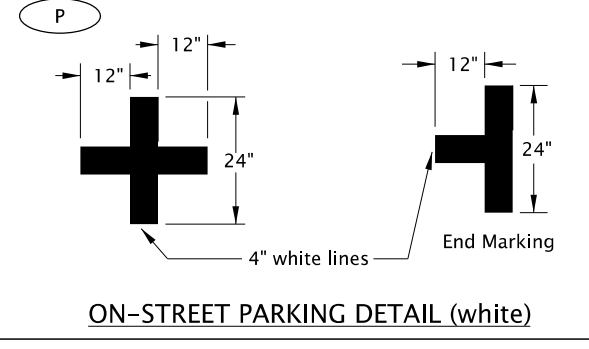
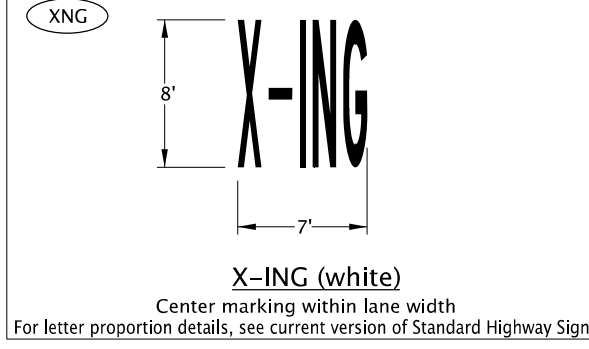
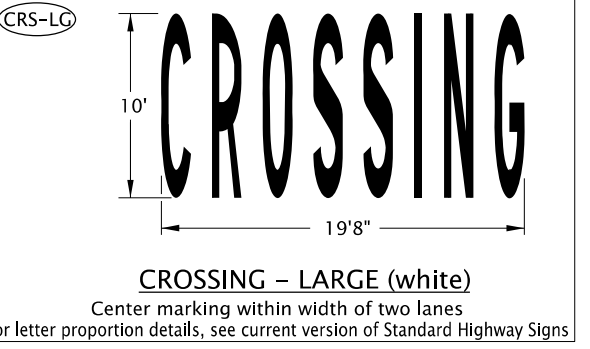
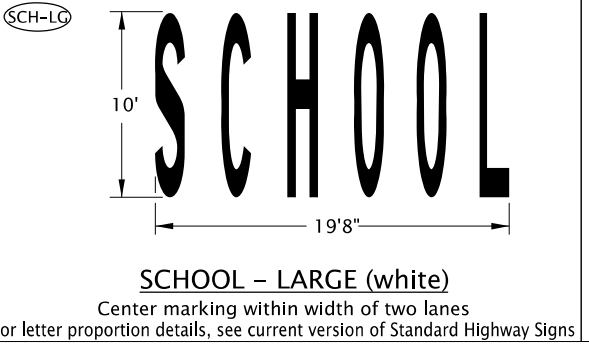
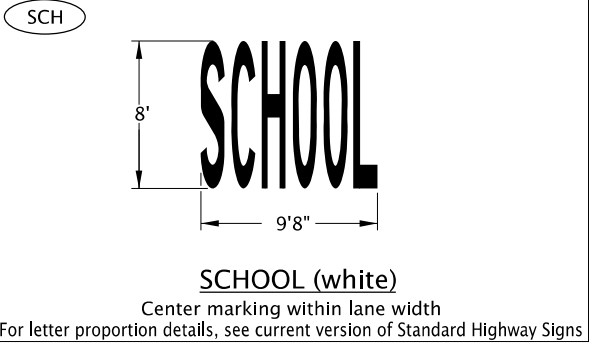
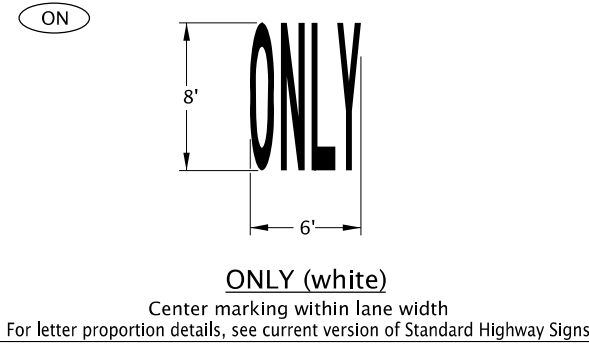
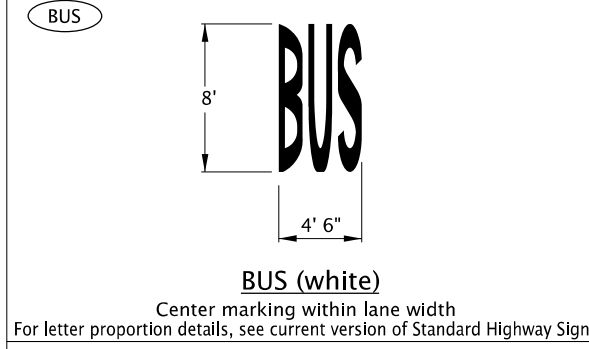
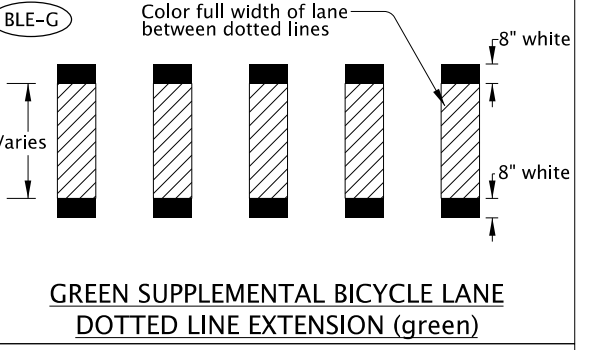
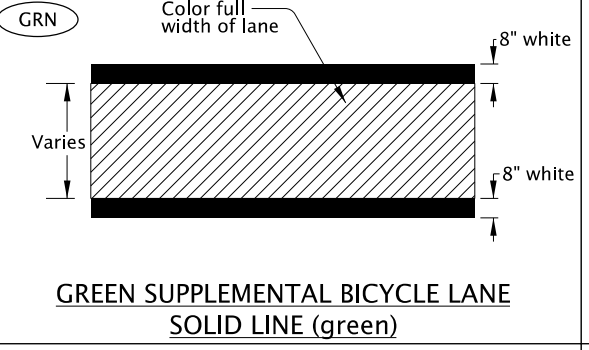
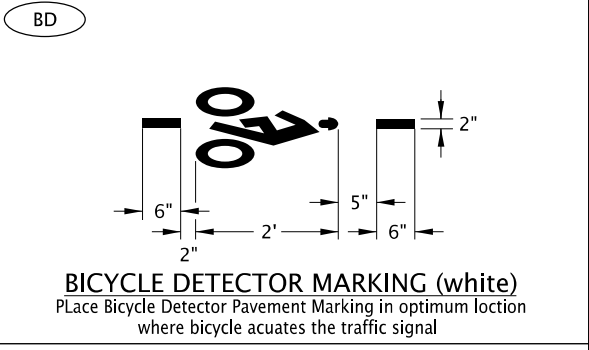
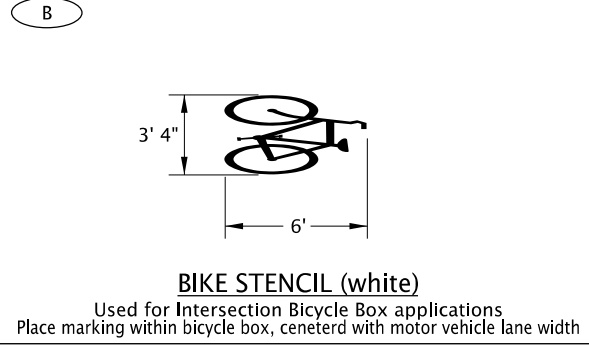
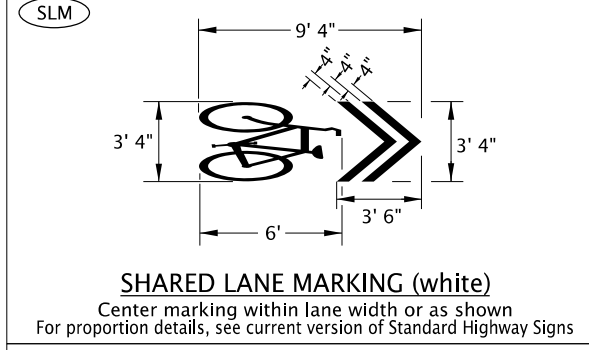
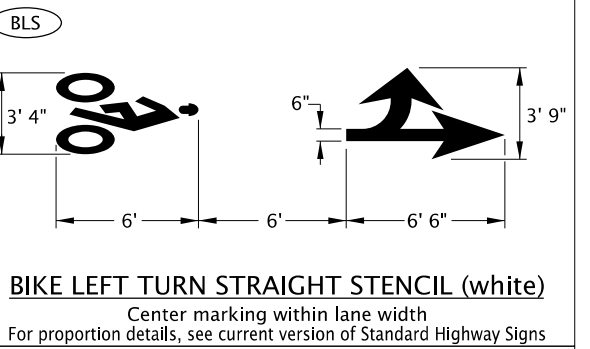
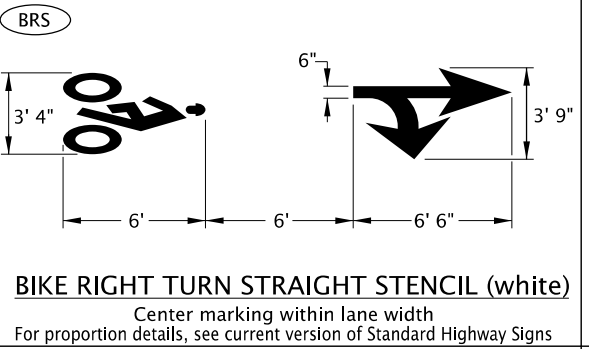
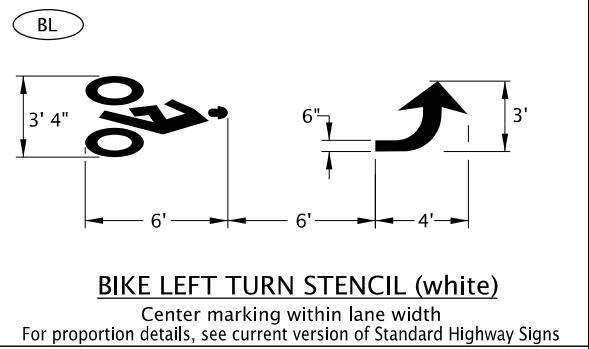
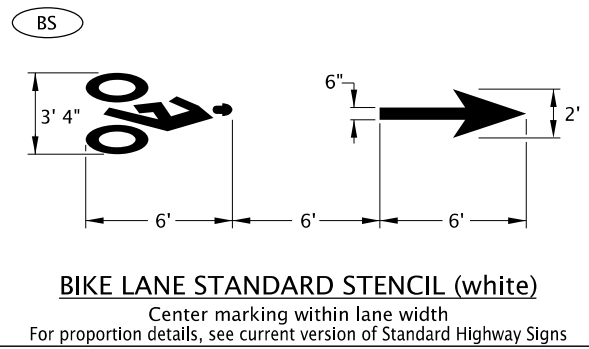
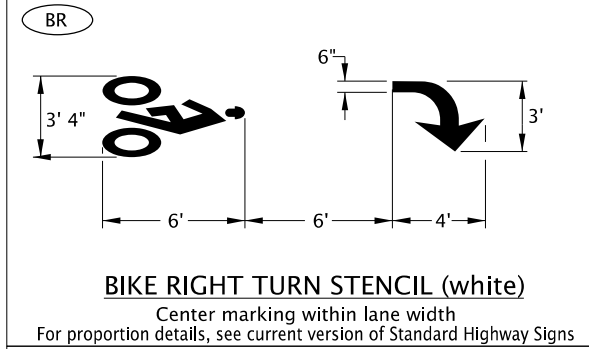
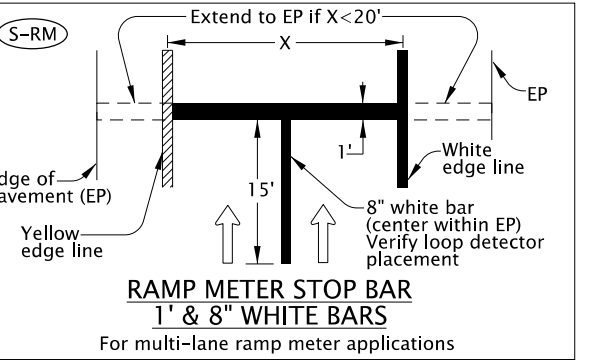
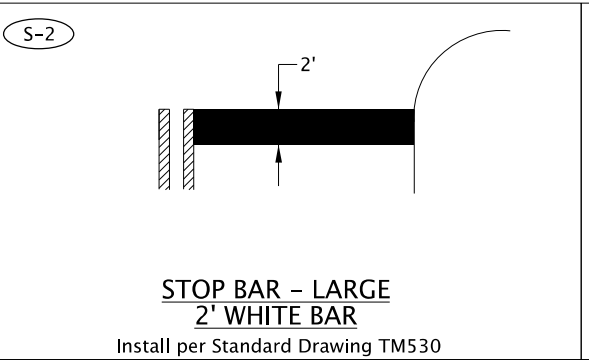
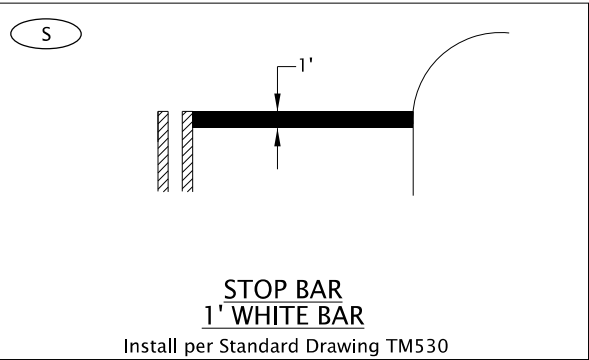
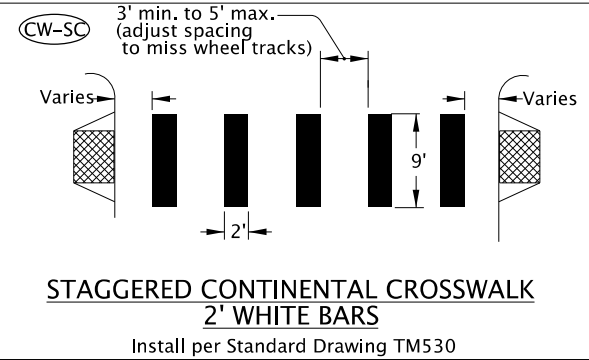
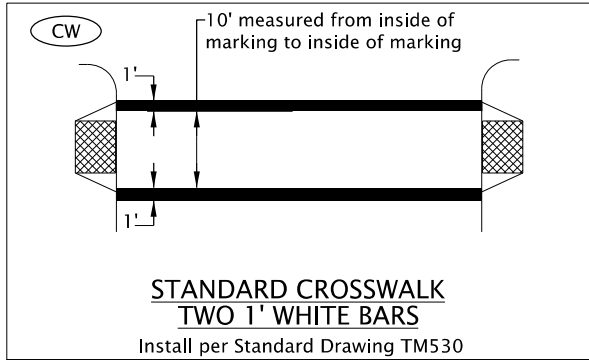

General Note:
1. Arrow, letter, and bike symbol dimensions nominal.

LEGEND
← Direction of Travel

The selection and use of this Standard Drawing, while designed in accordance with generally accepted engineering principles and practices, is the sole responsibility of the user and should not be used without first consulting a Registered Professional Engineer.

All materials shall be in accordance with the current Oregon Standard Specifications.

OREGON STANDARD DRAWINGS

**PAVEMENT MARKING
STANDARD DETAIL BLOCKS**

2024

DATE	REVISION	DESCRIPTION
07-2022		Added note for measurement of Standard Crosswalk

CALC. BOOK NO. - - -	N/A - - -	SDR DATE - 07-08-2022	TM503
----------------------	-----------	-----------------------	--------------

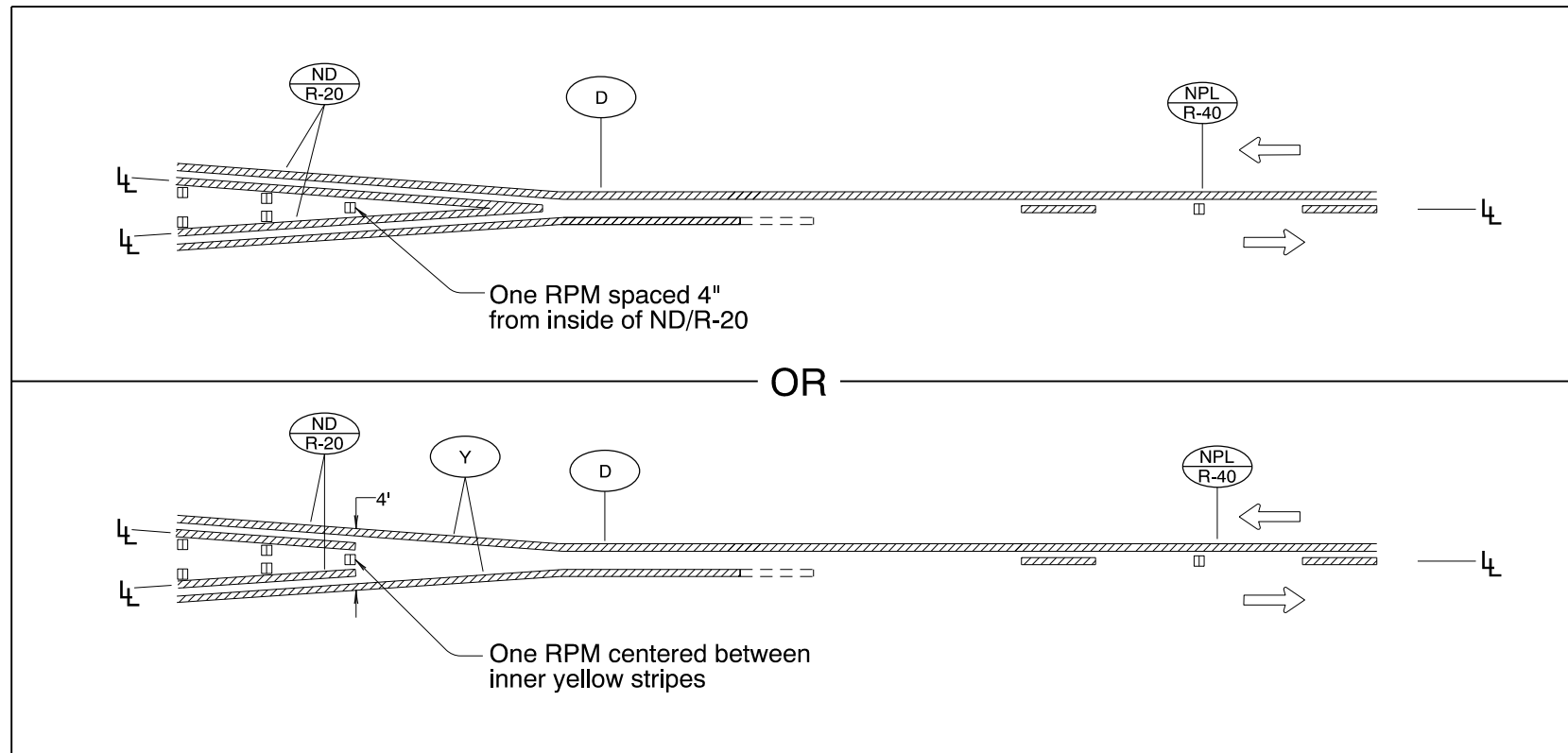

MEDIAN WIDTH TRANSITION

(TWO NARROW DOUBLE YELLOW LINES TO ONE-DIRECTION NO-PASSING LINE)
 (Refer to TM539 for additional details)

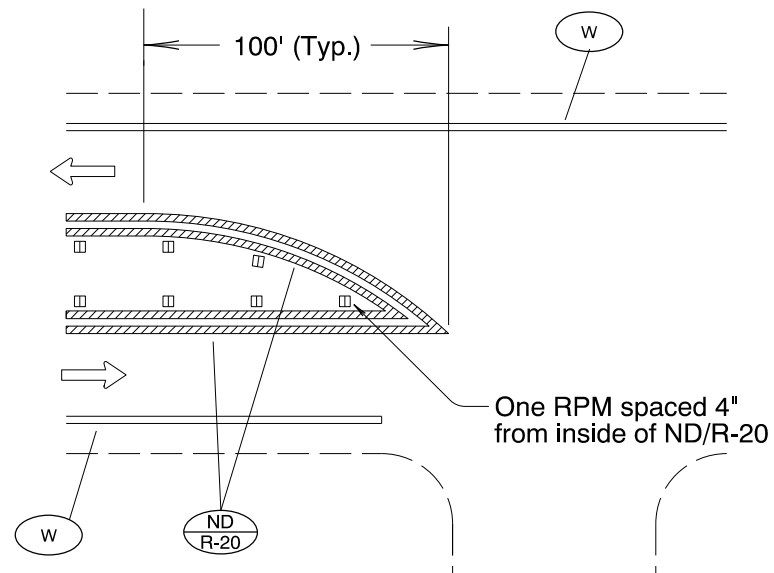

MEDIAN BULLNOSE DETAIL

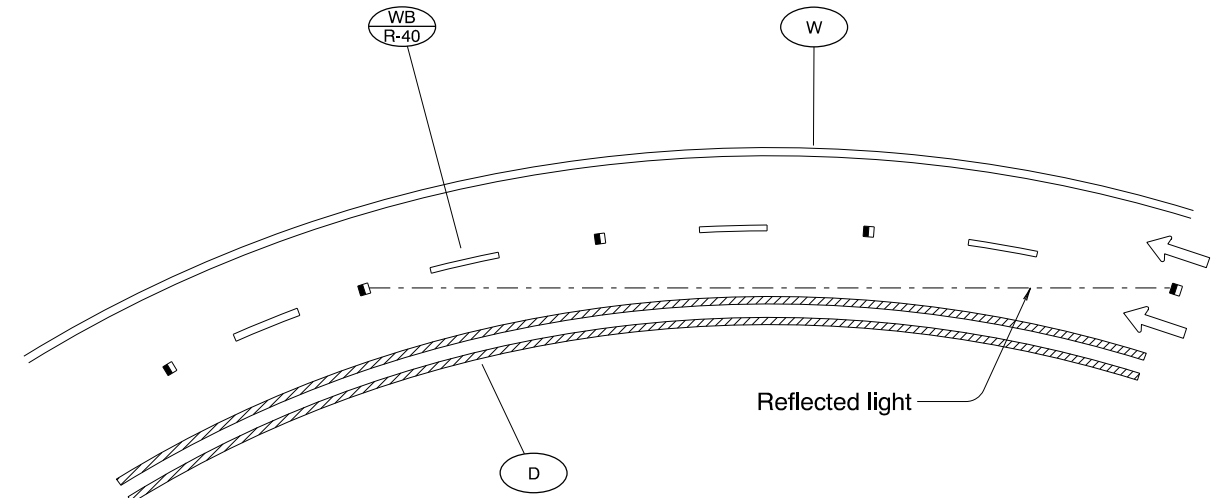

NOTE:

On one way sections the marker shall be installed with the reflective surface aimed to direct the reflected light back three markers.

(a) PAVEMENT MARKER INSTALLATION FOR MONO-DIRECTIONAL RAISED PAVEMENT MARKERS

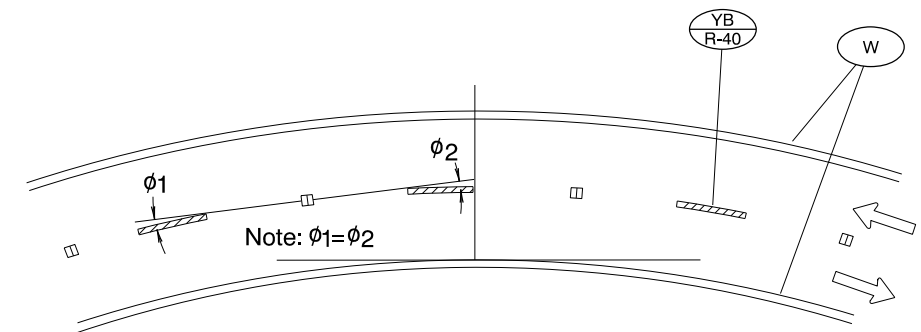

(b) PAVEMENT MARKER INSTALLATION FOR BI-DIRECTIONAL RAISED PAVEMENT MARKERS

PAVEMENT MARKER INSTALLATION ON HORIZONTAL CURVES

LEGEND

- Mono-Directional White (marker reflects white to left in this symbol)
- Bi-Directional Yellow (marker reflects yellow to both the left and right in this symbol)
- Increasing stationing from left to right
- ← Direction of Travel
- ⊥ Lane line dimensions are shown on the striping plans.

To be accompanied by Standard Dwg. Nos. TM500 thru TM504

All materials shall be in accordance with the current Oregon Standard Specifications.	
OREGON STANDARD DRAWINGS	
PAVEMENT MARKERS	
2024	
DATE	REVISION DESCRIPTION
CALC. BOOK NO. N/A	SDR DATE 01-JUL-2015
TM515	

Effective Date: December 1, 2023 – May 31, 2024

06-JUL-2022

TM530.dgn

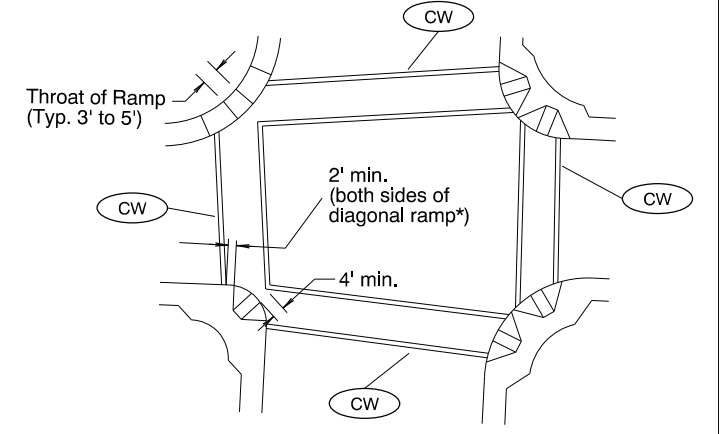
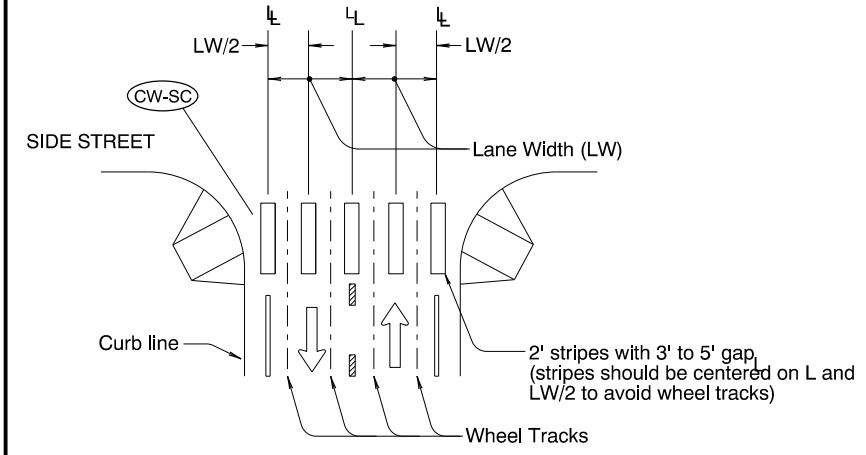
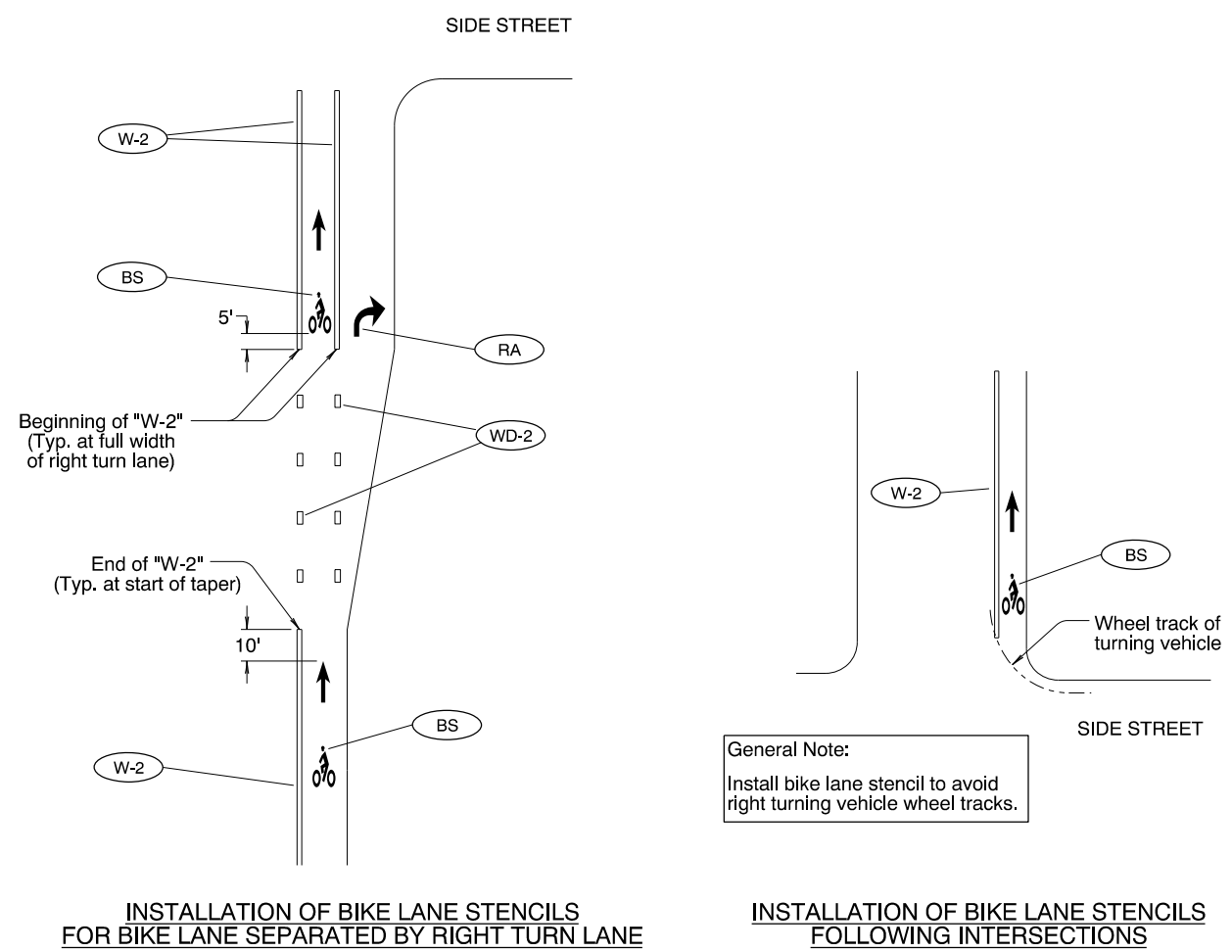
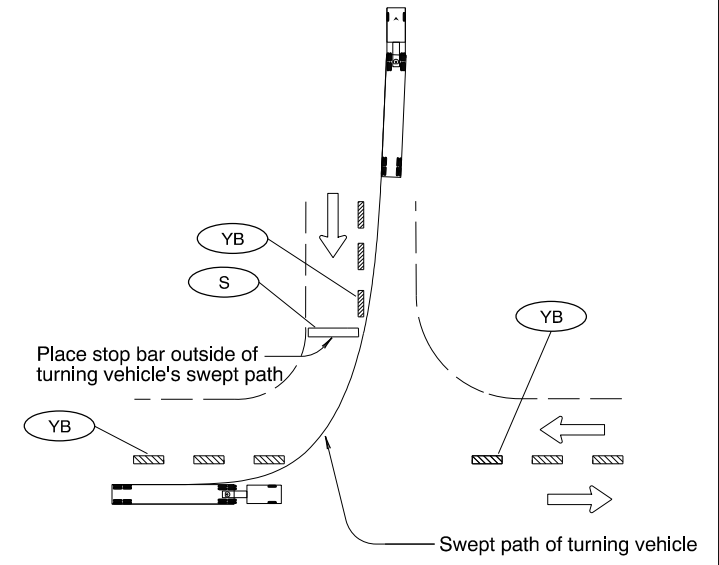
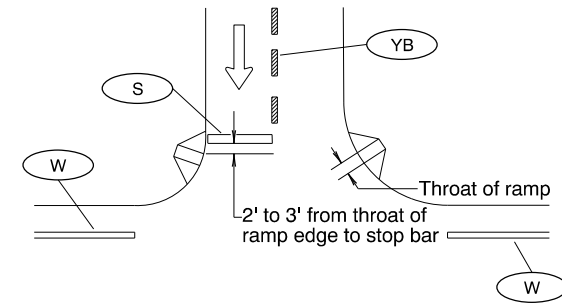
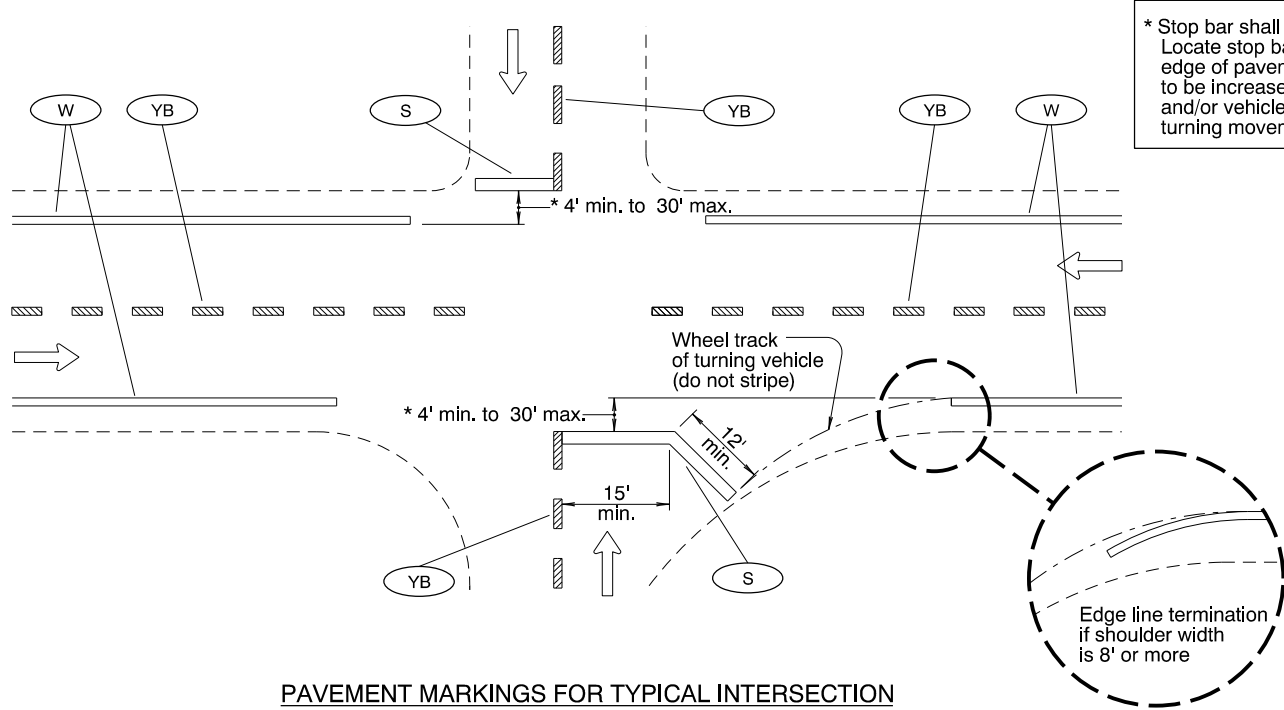

General Note:
1. Install crosswalk bars such that the throat of the ADA ramp is entirely within crosswalk markings, or 5' back of extended fog line, edge of pavement, or curb face.

LEGEND

← Direction of Travel

L - Lane line dimensions are shown on the striping plans

To be accompanied by Standard Dwg. Nos. TM500 thru TM504

The selection and use of this Standard Drawing, while designed in accordance with generally accepted engineering principles and practices, is the sole responsibility of the user and should not be used without first consulting a Registered Professional Engineer.

All materials shall be in accordance with the current Oregon Standard Specifications.

OREGON STANDARD DRAWINGS

INTERSECTION PAVEMENT MARKINGS (CROSSWALK, STOP BAR & BIKE LANE STENCIL)

2024

DATE	REVISION	DESCRIPTION
07-2022	Added Roadway Standard Drawing reference to detail for clarity	

CALC. BOOK NO. - - - -	N/A - - - -	SDR DATE - 06-JUL-2022	TM530
------------------------	-------------	------------------------	--------------

Effective Date: December 1, 2023 - May 31, 2024

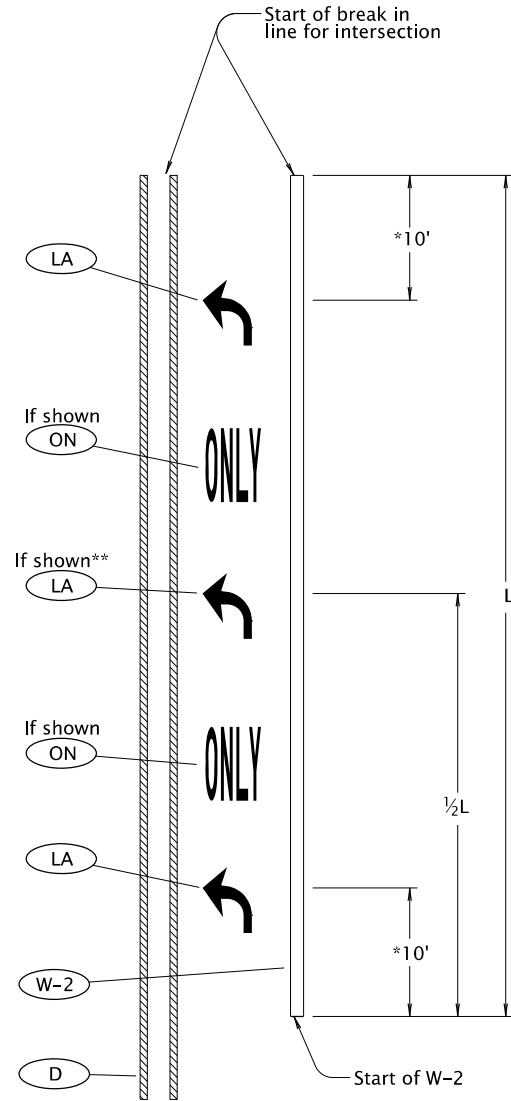

LANE USE ARROW PLACEMENT FOR TURN LANE
DETAIL "A"

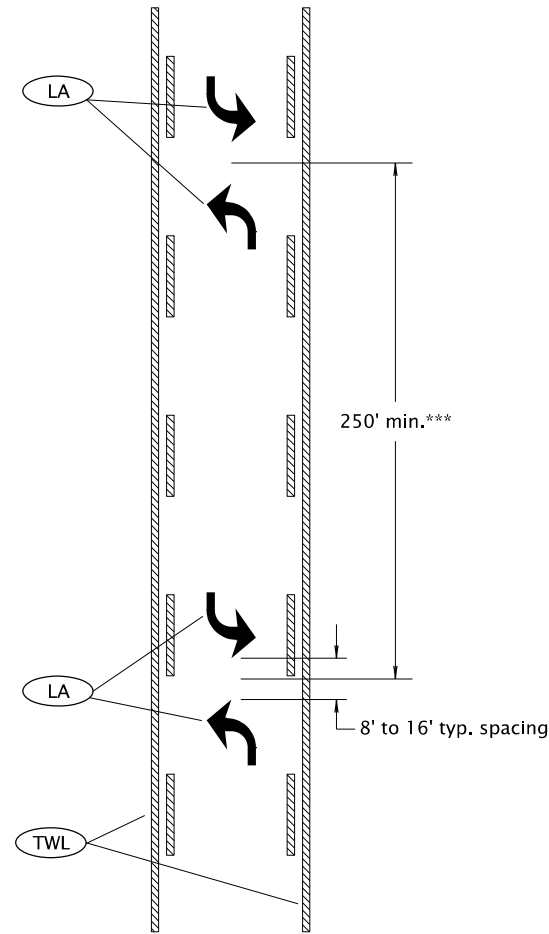

TWO-WAY LEFT TURN LANE ARROW PLACEMENT
DETAIL "B"

General Notes:

- 1) Center pavement marking legends within the lane.
- 2) Placement of lane use arrows with respect to the 8" wide white line (W-2) channelization shown in Detail "A" applies to both left and right turn lanes.
- 3) Center "ONLY" markings between lane use arrows.

* 15' when installing elongated arrows.

** When L is greater than 400', install 3rd lane use arrow at 1/2 L as shown in Detail "A".

*** Double arrows to be placed at even intervals, proportioned within block or as shown.

To be accompanied by Standard Dwg. Nos. TM500 thru TM504

The selection and use of this Standard Drawing, while designed in accordance with generally accepted engineering principles and practices, is the sole responsibility of the user and should not be used without first consulting a Registered Professional Engineer.

All materials shall be in accordance with the current Oregon Standard Specifications.

OREGON STANDARD DRAWINGS

TURN ARROW MARKING DETAILS

2024

DATE	REVISION	DESCRIPTION
07-2020		Extended accompanied by drawings to Include TM504
CALC. BOOK NO.	N/A	SDR DATE
		07-01-2020

TM531

Effective Date: December 1, 2023 – May 31, 2024

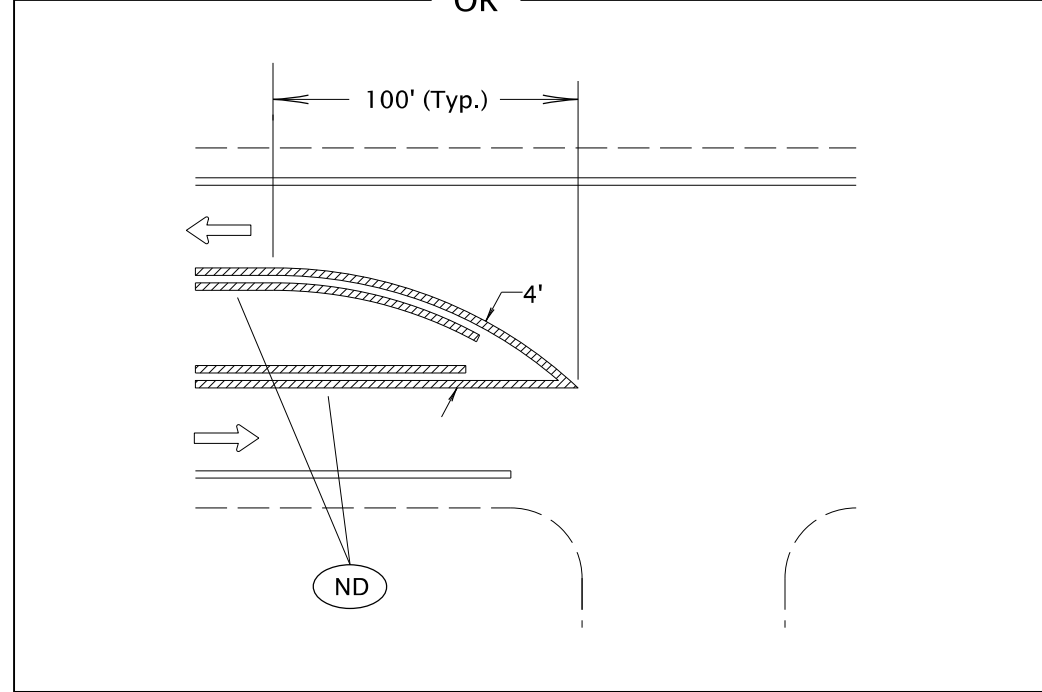
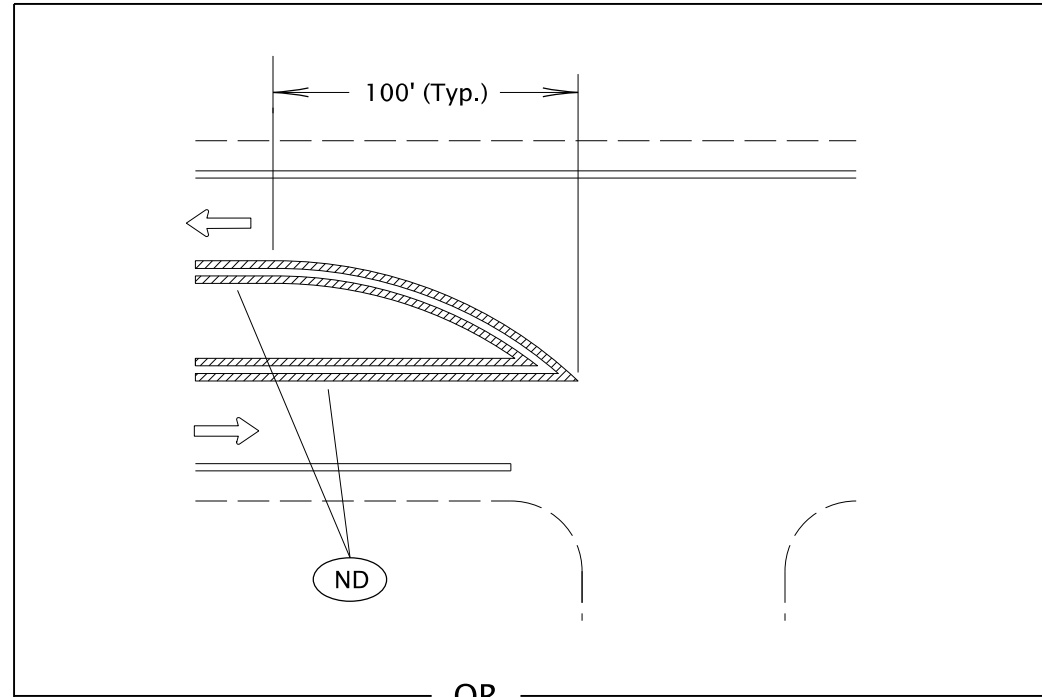

MEDIAN BULLNOSE DETAIL

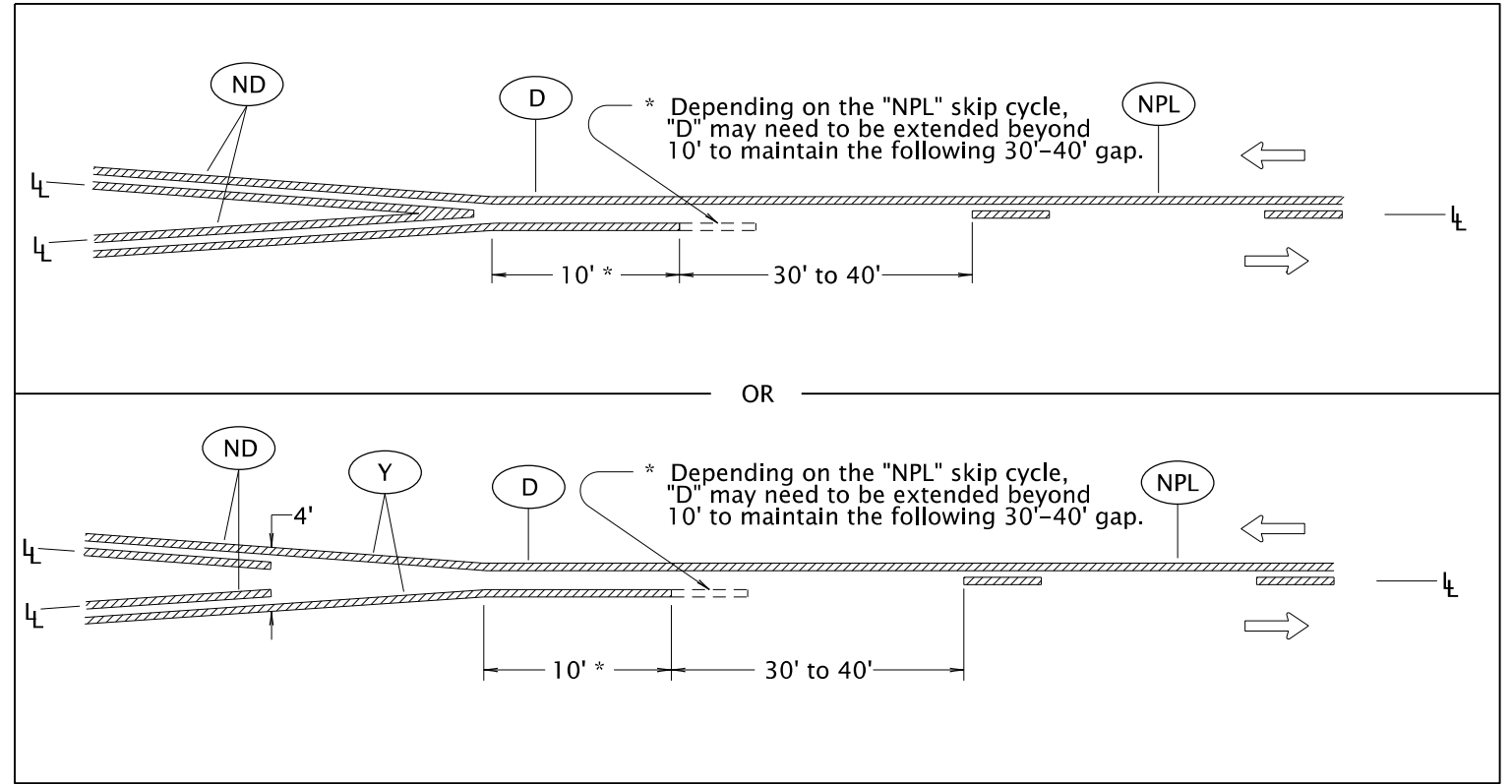

MEDIAN WIDTH TRANSITION
(TWO NARROW DOUBLE YELLOW LINES TO ONE-DIRECTION NO-PASSING LINE)

- LEGEND**
- ← Increasing stationing from left to right
 - ← Direction of Travel
 - ⊥ Lane line dimensions are shown on the striping plans

To be accompanied by Standard Dwg. Nos. TM500 thru TM504

All materials shall be in accordance with the current Oregon Standard Specifications.	
OREGON STANDARD DRAWINGS	
MEDIAN AND LEFT TURN CHANNELIZATION DETAILS	
2024	
DATE	REVISION DESCRIPTION
07-2020	Extended accompanied by drawings to Include TM504
CALC. BOOK NO.	N/A
SDR DATE	07-01-2020
TM539	

Effective Date: December 1, 2023 – May 31, 2024

The selection and use of this Standard Drawing, while designed in accordance with generally accepted engineering principles and practices, is the sole responsibility of the user and should not be used without first consulting a Registered Professional Engineer.

07-01-2020
TM560.dgn

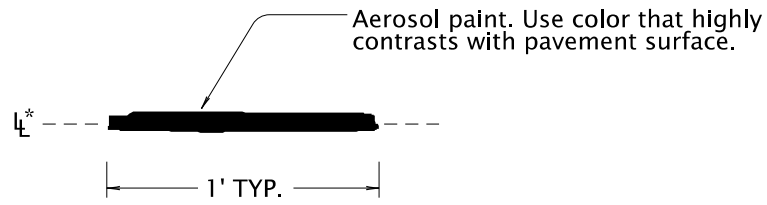

CONTROL POINT

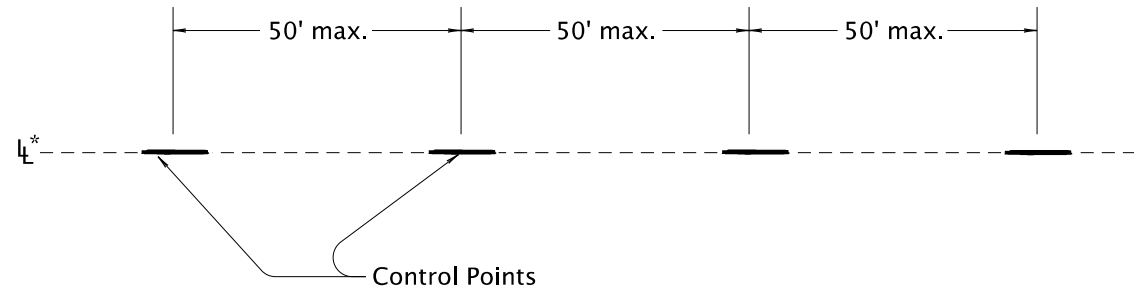

CONTROL POINT LAYOUT - TANGENT SECTIONS

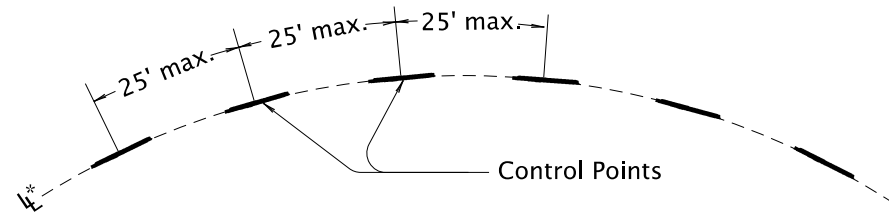

CONTROL POINT LAYOUT - CURVE SECTIONS

General note:

1.) Use control points to make continuous narrow guideline as specified.

* Control points are placed along the lane line for all longitudinal lines except the following:

ND For center lines only A control point layout 4" offset from the lane line is required for a ND line when used as a center line.

LEGEND

ℓ* - Lane line dimensions are shown on the striping plans.

To be accompanied by Standard Dwg. Nos. TM500 thru TM504

<p><i>The selection and use of this Standard Drawing, while designed in accordance with generally accepted engineering principles and practices, is the sole responsibility of the user and should not be used without first consulting a Registered Professional Engineer.</i></p>		<p>All materials shall be in accordance with the current Oregon Standard Specifications.</p>	
		<p>OREGON STANDARD DRAWINGS</p>	
		<p>ALIGNMENT LAYOUT: GENERAL</p>	
		<p>2024</p>	
DATE	REVISION	DESCRIPTION	
07-2020		Extended accompanied by drawings to include TM504	
CALC. BOOK NO.	N/A	SDR DATE	07-01-2020
			TM560

Effective Date: December 1, 2023 - May 31, 2024

07-01-2020

TM561.dgn

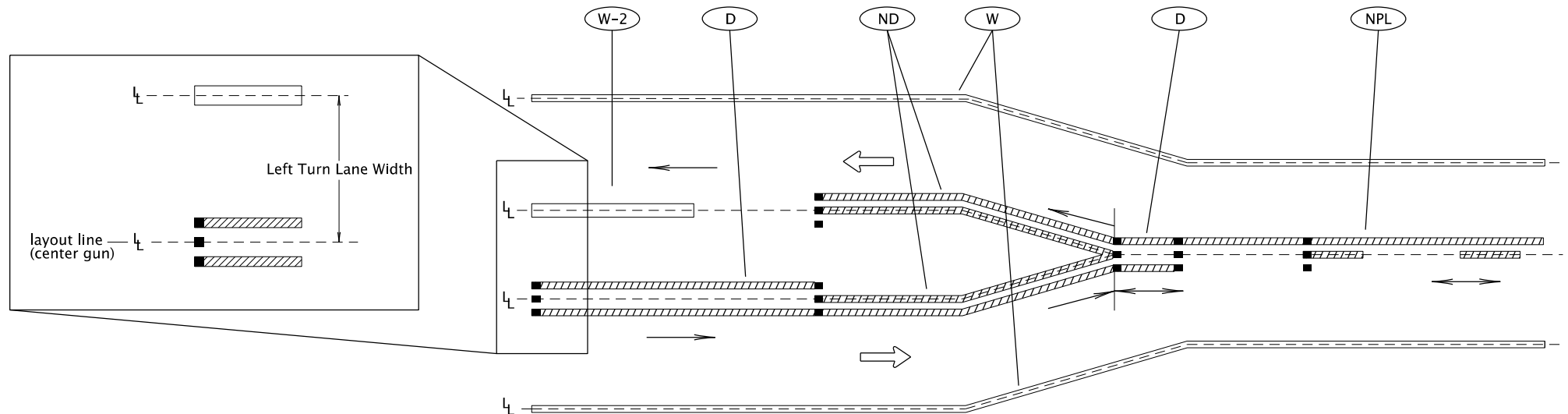

LEFT TURN LANE ALIGNMENT LAYOUT

- General note:
- 1) Install control points for pavement marking alignment layout along the center gun location.
 - 2) Increasing stationing from left to right

LEGEND

- ← Direction Of Travel and Thru Traffic Side.
- └ Lane line dimensions are shown on the striping plans.
- ↔ Direction of striping truck (may go either direction)
- Direction of striping truck (may go one direction only)
- Three gun installation system (center dot represents center gun)

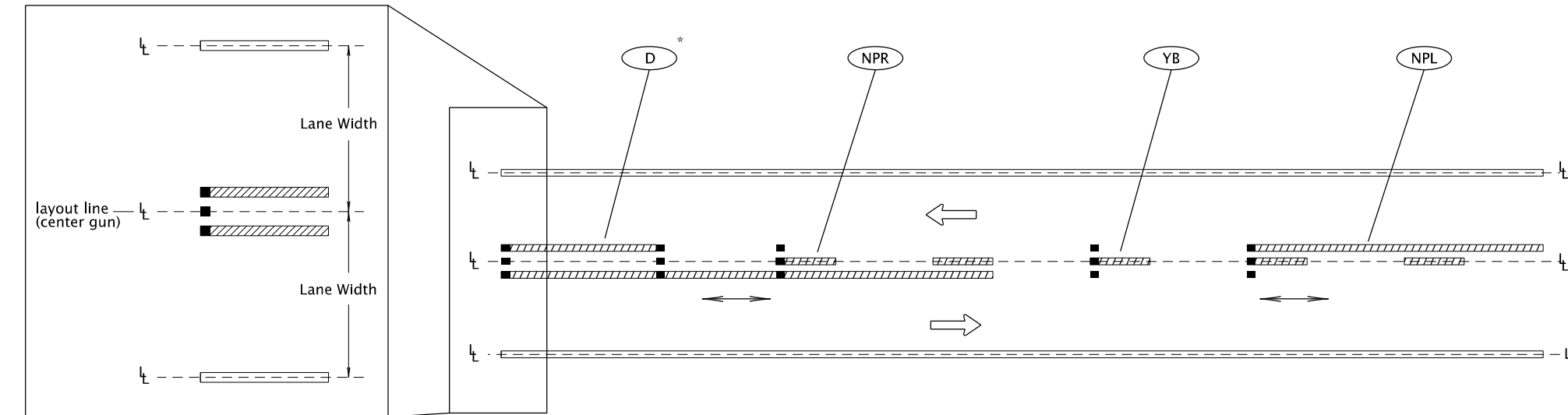

CENTERLINE ALIGNMENT LAYOUT

*When ND is used as centerline markings, a control point layout 4" offset from the lane line is required.

Line Types requiring control points to be 4" offset from lane line:
ND
For centerlines only

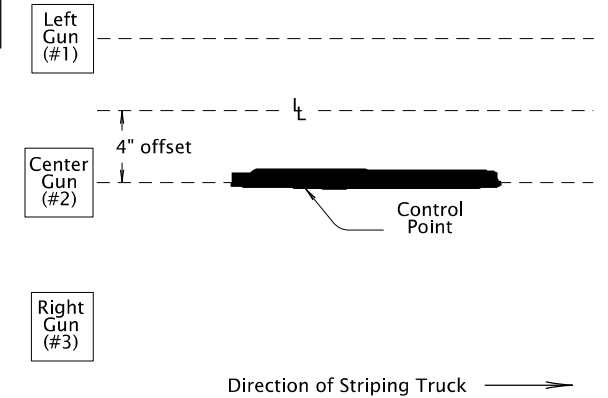

4" Offset of Lane Line and Center Gun

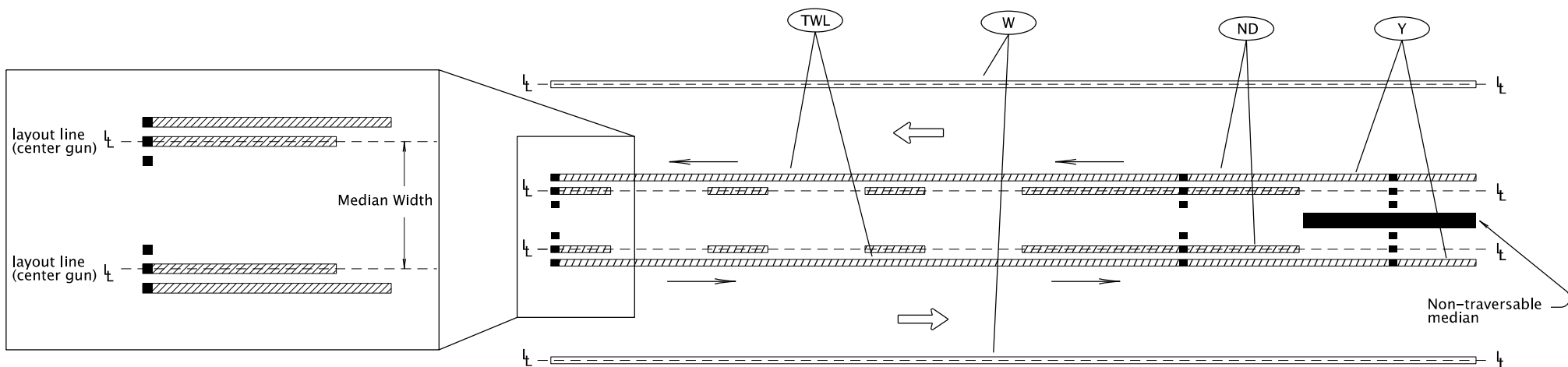

MEDIAN ALIGNMENT LAYOUT

To be accompanied by Standard Dwg. Nos. TM500 thru TM504

The selection and use of this Standard Drawing, while designed in accordance with generally accepted engineering principles and practices, is the sole responsibility of the user and should not be used without first consulting a Registered Professional Engineer.

All materials shall be in accordance with the current Oregon Standard Specifications.

OREGON STANDARD DRAWINGS

**ALIGNMENT LAYOUT:
LEFT TURN LANE,
CENTERLINE & MEDIANS**

2024

DATE	REVISION	DESCRIPTION
07-2020		Extended accompanied by drawings to Include TM504

CALC. BOOK NO.	N/A	SDR DATE	07-01-2020	TM561
----------------	-----	----------	------------	--------------

Effective Date: December 1, 2023 – May 31, 2024

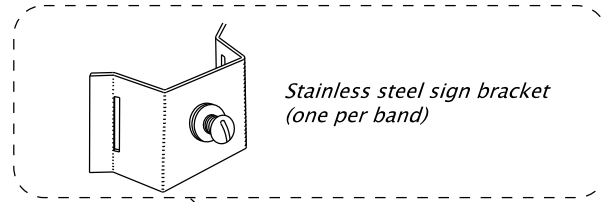

Stainless steel sign bracket
(one per band)

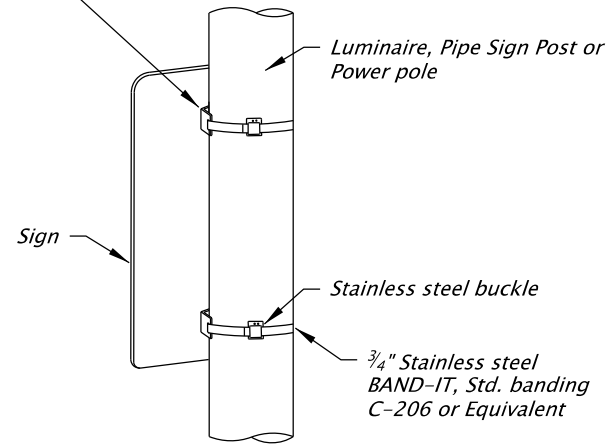

Signs mounted to vertical posts that use stainless steel clamps shall not be wider than 36". Use 2 clamps for all signs less than 48" in height and 3 clamps for signs 48" to 60" in height.

STAINLESS STEEL CLAMP (SSC) DETAIL

No Scale

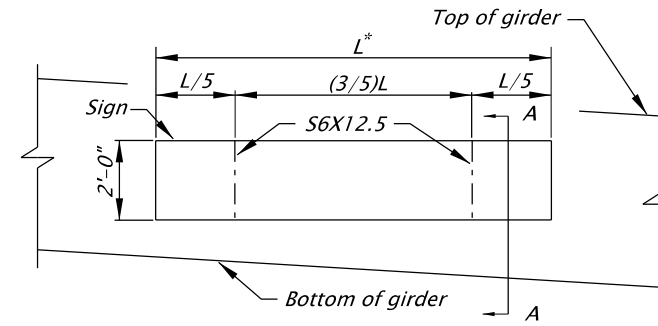

* - L maximum is 14'-0".

SIGN ELEVATION

No Scale

S6X12.5 - A36
Hot Dipped Galvanized

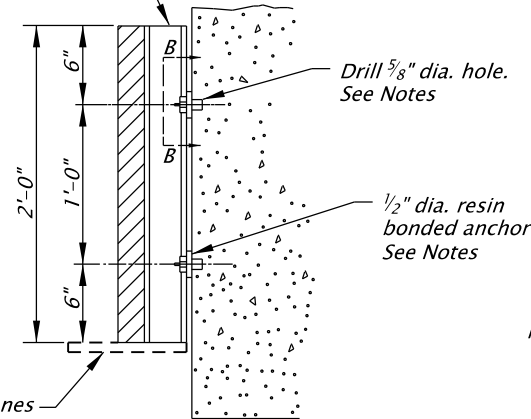

SECTION A-A

No Scale

Signs mounted over travel lanes shall use the SIGN SUPPORT BRACKET DETAIL shown on TM618

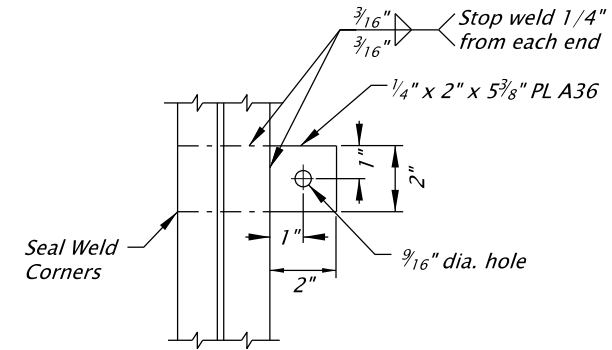

SECTION B-B

No Scale

Notes:

1. Install resin bonded anchors according to Section 00535.
2. Resin bonded anchors shall conform to ASTM A307.
3. The hole depths shall develop the pullout strength specified in Table 00535-1.
4. Tighten 1/2" dia. anchors using 16 ft-lb of torque for waxed galvanized and 40 ft-lb of torque for galvanized only connections.

ROAD NAME SIGN STRUCTURE MOUNT DETAIL

GENERAL NOTES

1. For Secondary Sign Mounts See TM678.

<p>The selection and use of this Standard Drawing, while designed in accordance with generally accepted engineering principles and practices, is the sole responsibility of the user and should not be used without first consulting a Registered Professional Engineer.</p>		All materials shall be in accordance with the current Oregon Standard Specifications.	
		OREGON STANDARD DRAWINGS	
		SIGN MOUNTS	
		2024	
DATE	REVISION	DESCRIPTION	
CALC. BOOK NO.	N/A	SDR DATE	06-JUL-2015
			TM677

TAPER TYPES & FORMULAS	
TAPER	FORMULA
Merging (Lane Closure)	"L"
Shifting	"L"/2 or 1/2"L"
Shoulder Closure	"L"/3 or 1/3"L"
Flagging (See Drg. TM850)	50' - 100'
Downstream (Termination)	Varies (See Drawings)

★ Use Pre-Construction Posted Speed to select the Speed from the Tables below:

TEMPORARY BARRIER FLARE RATE TABLE	
★ SPEED (mph)	MINIMUM FLARE RATE
≤ 30	8:1
35	9:1
40	10:1
45	12:1
50	14:1
55	16:1
60	18:1
65	19:1
70	20:1

MINIMUM LENGTHS TABLE					
★ SPEED (mph)	"L" VALUE FOR TAPERS (ft)				BUFFER "B" (ft)
	W ≤ 10	W = 12	W = 14	W = 16	
25	105	125	145	165	75
30	150	180	210	240	100
35	205	245	285	325	125
40	265	320	375	430	150
45	450	540	630	720	180
50	500	600	700	800	210
55	550	660	770	880	250
60	600	720	840	960	285
65	650	780	910	1000	325
70	700	840	980	1000	365
FREEWAYS					
55	1000	1000	1000	1000	250
60	1000	1000	1000	1000	285
65	1000	1000	1000	1000	325
70	1000	1000	1000	1000	365

NOTES:
 • For Lane closures where W < 10', use "L" value for W = 10'.
 • For Shoulder closures where W < 10', use "L" value for W = 10' or calculate "L" using formula, for Speeds ≥ 45: L = WS, Speeds < 45: L = S²W/60, S = Speed, W=Width

TRAFFIC CONTROL DEVICES (TCD) SPACING TABLE				
★ SPEED (mph)	Sign Spacing (ft)			Max. Channelizing Device Spacing (ft)
	A	B	C	
20 - 30	100	100	100	20
35 - 40	350	350	350	20
45 - 55	500	500	500	40
60 - 70	700	700	700	40
Freeway	1000	1500	2640	40

NOTES:
 • Place traffic control devices on 10 ft. spacing for intersection and access radii.
 • When necessary, sign spacing may be adjusted to fit site conditions.
 Limit spacing adjustments to 30% of the "A" dimension for all speeds.

NOTES:
 • When paved shoulders adjacent to excavations are less than four feet wide protect longitudinal abrupt edge as shown.
 • Use aggregate wedge when abrupt edge is 2 inches or greater.

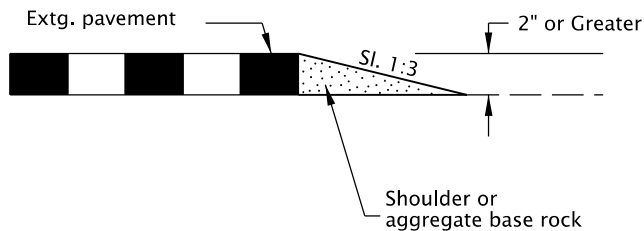

EXCAVATION ABRUPT EDGE

NOTES:
 • Abrupt edges may be created by paving, operations, excavations or other roadway work. Use abrupt edge signing for longitudinal abrupt edges of 1 inch or greater.
 • If the excavation is located on left side of traffic, replace the 8' B(III)R barricades with 8' B(III)L barricades and replace the "RIGHT" (CW21-8C) riders with "LEFT" (CW21-8A) riders.
 • Continue signing and other traffic control devices throughout excavation area at spacings shown.
 • If roll-up signs are used, attach the correct (CW21-9) plaques to the sign face using hook and loop fasteners. Place roll-up signs in advance of barricades.

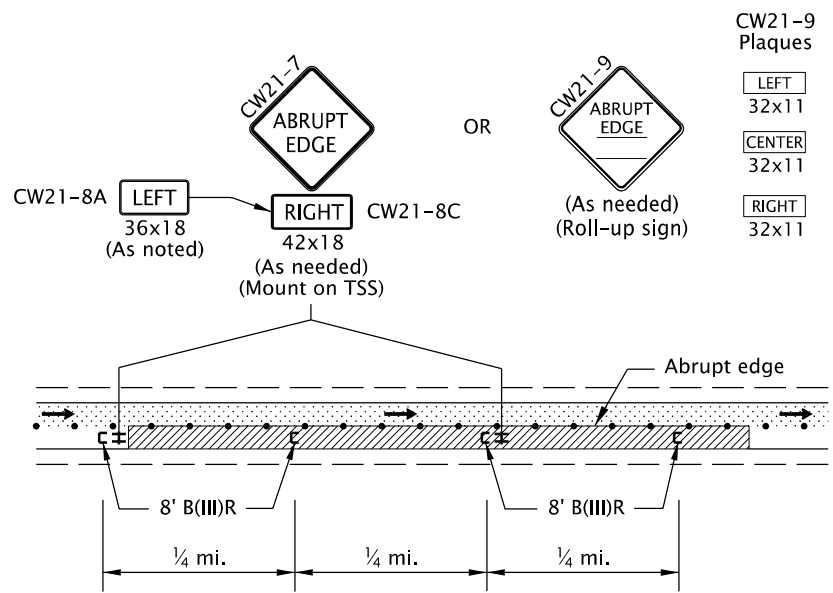

TYPICAL ABRUPT EDGE DELINEATION

NOTES:
 • Install PCMS beyond the outside shoulder, when possible.
 • Use the appropriate type of barricade panels for PCMS location. Right shoulder, use Type B(III)R. Left shoulder, use Type B(III)L.
 • Use six drums in shoulder taper on 20' spacing. The drums and barricade may be omitted when PCMS is placed behind a roadside barrier.
 • Detail as shown is used for trailered and non-crashworthy components of:
 • Portable Traffic Signals
 • Smart Work Zone Systems

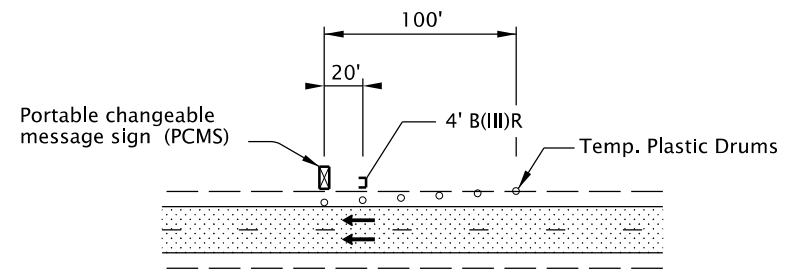

PORTABLE CHANGEABLE MESSAGE SIGN (PCMS) INSTALLATION

NOTES:
 • Install Flagger Station Lighting beyond the outside shoulder, where practical.
 • Use six tubular markers in shoulder taper on 10' spacing.
 • Place cart / generator / power supply off of the shoulder, as far as practical.

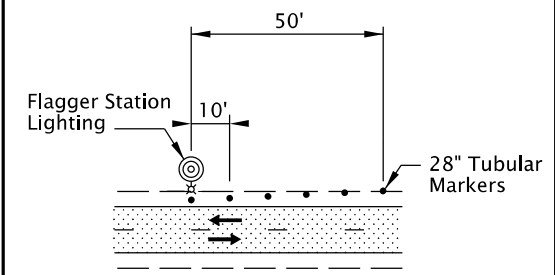

FLAGGER STATION LIGHTING DELINEATION

GENERAL NOTES FOR ALL TCP DRAWINGS:
 • Signs and other Traffic Control Devices (TCD) shown are the minimum required.
 • Place a barricade approx. 20' ahead of all sequential arrow boards.
 • Arrows shown in roadway are directional arrows to indicate traffic movements.
 • All signs are 48" x 48" unless otherwise shown. Use fluorescent orange sheeting for the background of all temporary warning signs.
 • All diamond shaped warning signs mounted on barrier sign supports shall be 36" by 36". All other signs mounted on barrier sign supports shall not exceed 12 sq. ft. in total sign area.
 • Low speed highways have a pre-construction posted speed of 40 mph or less. High speed highways have a pre-construction posted speed of 45 mph or higher.
 • Do not locate sign supports in locations designated for bicycle or pedestrian traffic.
 • Combine drawing details to complete temporary traffic control for each work activity.
 • Coordinate and control pedestrian movements through a Temporary Accessible Route using Flaggers, Traffic Control Measures, or as directed.
 • To be accompanied by Dwg. Nos. TM820 & TM821.

The selection and use of this Standard Drawing, while designed in accordance with generally accepted engineering principles and practices, is the sole responsibility of the user and should not be used without first consulting a Registered Professional Engineer.

All materials shall be in accordance with the current Oregon Standard Specifications.			
OREGON STANDARD DRAWINGS			
TABLES, ABRUPT EDGE AND PCMS DETAILS			
2024			
DATE	REVISION DESCRIPTION		
07-2022	Added a note for TPARs		
CALC. BOOK NO.	N/A	SDR DATE	01-JUL-2022
			TM800

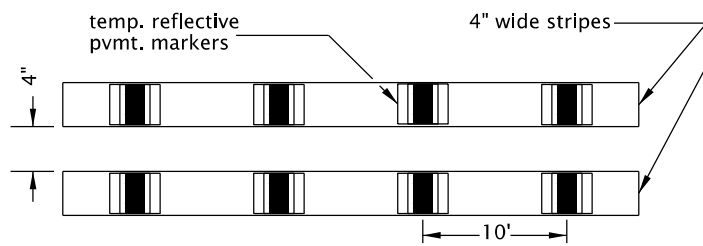

LAYOUT "A"
(Supplemented double solid lines)

TYPICAL APPLICATIONS:

- To prohibit lane changes or passing (include appropriate regulatory signs).
- Freeway or multilane shifts and crossovers.
- For projects in place through winter months.
- Two-lane, two-way centerlines.

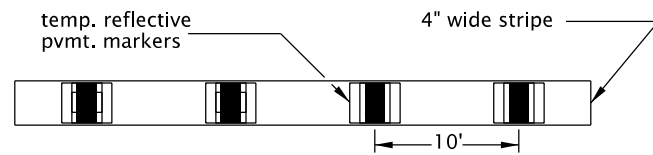

LAYOUT "B"
(Supplemented solid line)

TYPICAL APPLICATIONS:

- Alignment shifts or crossovers.
- To discourage lane changes in multilane sections.
- For projects in place through winter months.

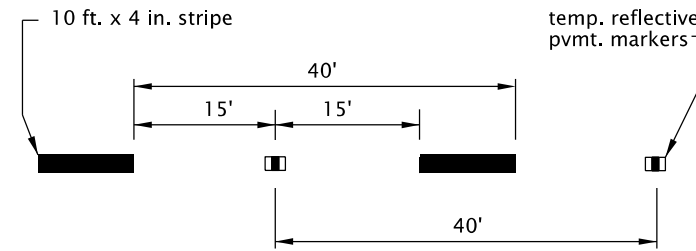

LAYOUT "C"
(Supplemented broken lines)

TYPICAL APPLICATIONS:

- Freeway and multilane broken lines.
- High ADT 2 lane roads (greater than 10,000).
- For projects in place through winter months.

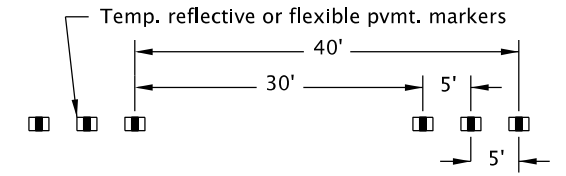

LAYOUT "D"
(Simulated broken lines)

TYPICAL APPLICATIONS:

- During staging on finished/existing surfaces.
- HMAC intermediate surfaces.
- Emulsified asphalt surface treatments (chip seals) where permanent pavement markings cannot be placed within two weeks.

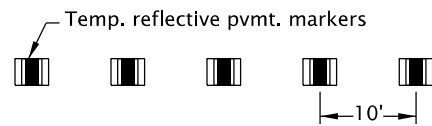

LAYOUT "E"
(Simulated Solid Lines)

TYPICAL APPLICATIONS:

- Alignment shifts or crossovers.
- To discourage lane changes in multilane sections.
- Edge lines for short durations, less than 14 days.

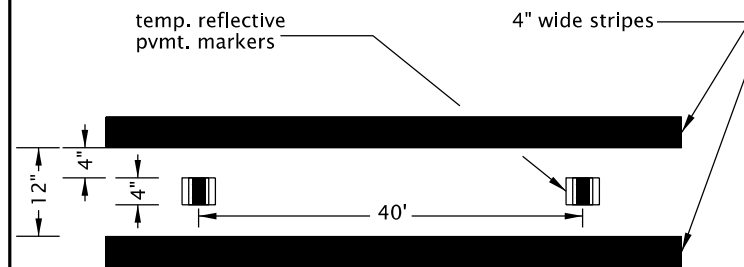

LAYOUT "F"
(Supplemented wide double solid lines)

TYPICAL APPLICATIONS:

- To prohibit lane changes or passing (include appropriate regulatory signs).
- 2 lane, 2 way centerlines.
- 2 lane, 1 way alignments on freeways or multi-lane highways.

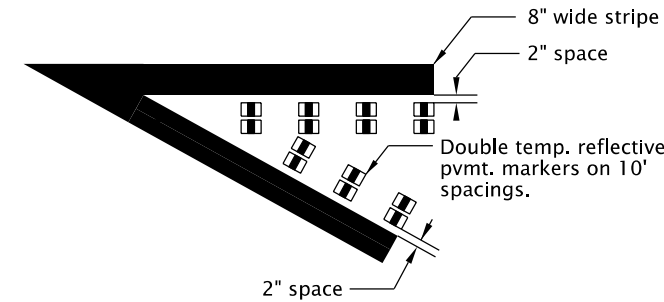

LAYOUT "G"
(Supplemented solid 8" line)

TYPICAL APPLICATIONS:

- Gore areas
- Alignment splits (bifurcations)

GENERAL NOTES FOR ALL DETAILS:

- When using Supplemented or Simulated lines:
 1. Yellow Bi-Directional Pavement Markers are required for Two-Way Traffic.
 2. White Mono-Directional Pavement Markers are required for one-way traffic or edge lines.
- Supplemented lines are painted lines enhanced with Reflective Pavement Markers.
- Simulated lines are Reflective Pavement Markers placed in a pattern to substitute for a painted line.
- Pavement marking colors shall conform to the MUTCD.

The selection and use of this Standard Drawing, while designed in accordance with generally accepted engineering principles and practices, is the sole responsibility of the user and should not be used without first consulting a Registered Professional Engineer.

All materials shall be in accordance with the current Oregon Standard Specifications.			
OREGON STANDARD DRAWINGS			
TEMPORARY PAVEMENT MARKINGS			
2024			
DATE	REVISION DESCRIPTION		
CALC. BOOK NO.	N/A	SDR DATE	01-JUL-2020
			TM810

01-JUL-2020
TM820.dgn

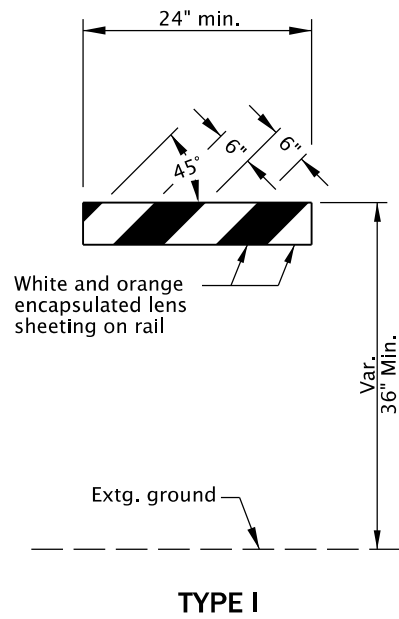

TYPE I

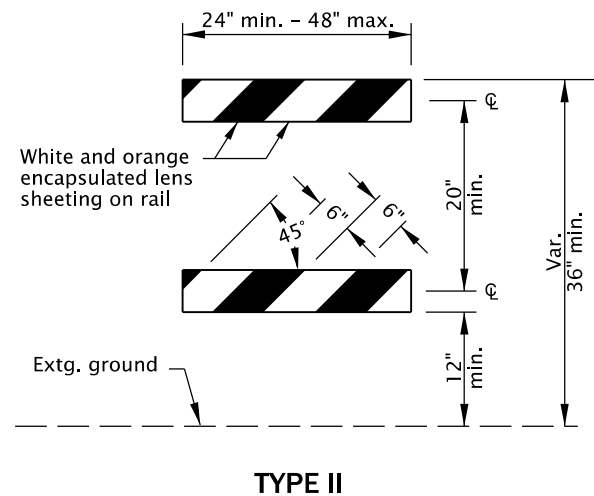

TYPE II

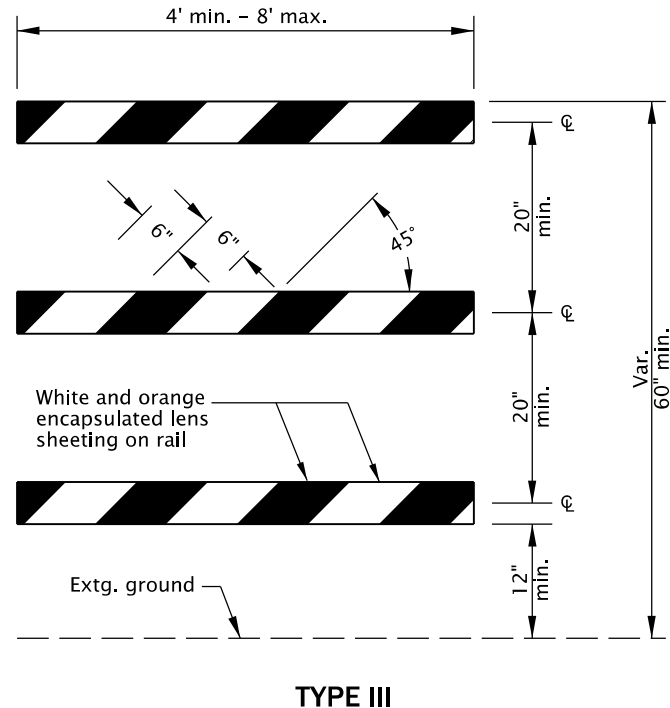

TYPE III

BARRICADE RAIL LAYOUT

- GENERAL NOTES FOR ALL DETAILS:**
- Sandbags (approximately 25 lb sack filled with sand) may be placed on lower frame to provide additional ballast.
 - Ballast shall not extend above bottom rail or be suspended from barricade.
 - For rails less than 36" long, 4" wide stripes shall be used.
 - Rails must be 8" min. to 12" max. in height.
 - Use barricades from ODOT Qualified Products List (QPL).
 - Use 4' Type III barricades where horizontal space is limited.
 - Do not block bike lanes or shoulders unless the facility is properly closed and signed.
 - Do not place barricades in sidewalks unless sidewalk is closed and a temporary pedestrian accessible route (TPAR) is signed according to the TCP. See Dwg. No. TM844.

- NOTES:**
- Markings for barricade rails shall slope downward at an angle of 45° in the direction traffic is to pass.
 - Where a barricade extends entirely across a roadway, it is desirable that the stripes slope downward in the direction toward which traffic must turn in detouring.
 - Where both right and left turns are provided for, slope the chevron striping downward in both directions from the center of the barricade.
 - For full roadway closures, the C or LR barricade may be used. Extend barricades completely across roadway unless access is required for local road users.

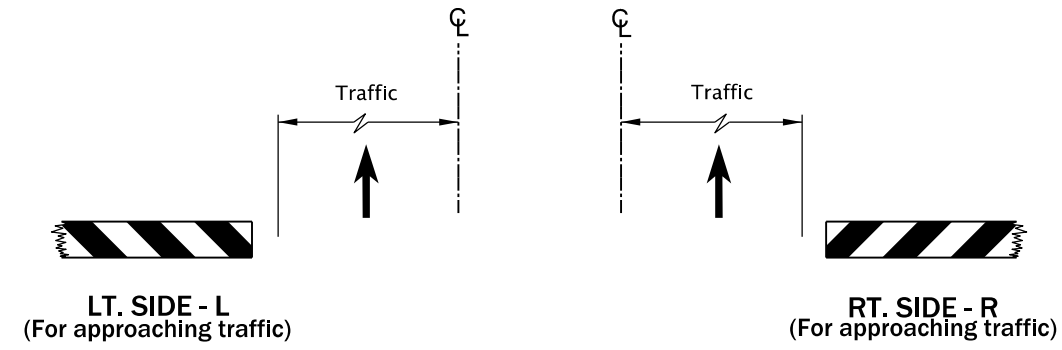
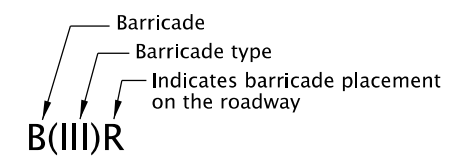

DIAGRAM FOR BARRICADE PLACEMENT AND SLOPE MARKING



BARRICADE NOTATION

The selection and use of this Standard Drawing, while designed in accordance with generally accepted engineering principles and practices, is the sole responsibility of the user and should not be used without first consulting a Registered Professional Engineer.

All materials shall be in accordance with the current Oregon Standard Specifications.			
OREGON STANDARD DRAWINGS			
TEMPORARY BARRICADES			
2024			
DATE	REVISION DESCRIPTION		
CALC. BOOK NO.	N/A	SDR DATE	01-JUL-2020
			TM820

14-JUL-2023

TM821.dgn

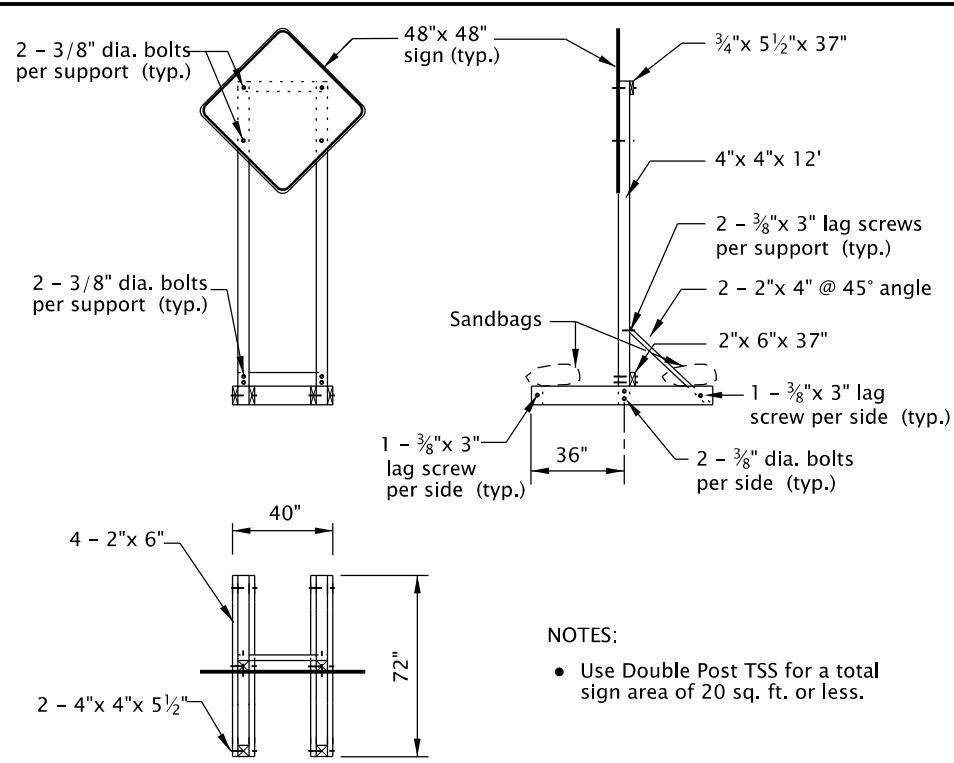

- NOTES:
- Use Double Post TSS for a total sign area of 20 sq. ft. or less.

DOUBLE POST DETAIL

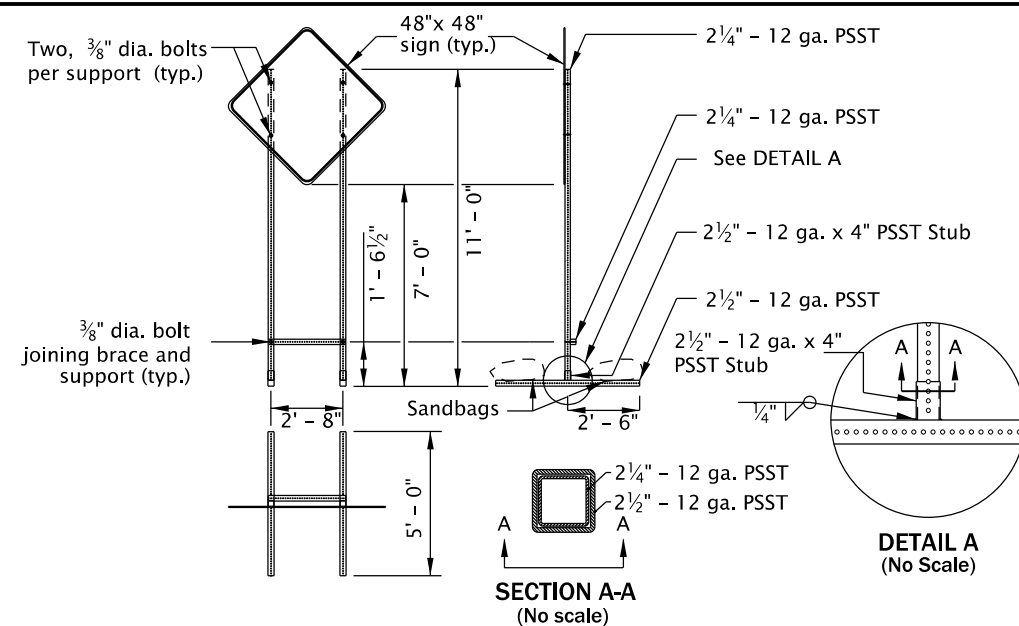

- NOTES:
- Use PSST TSS's for a total sign area of 16 sq. ft. or less.
 - All members shall have a minimum yield stress of 50 ksi.
 - Galvanize steel according to ASTM A653 with coating designation G90. Remove Galvanizing from steel before welding. Repair Galvanizing according to ASTM A780.
 - Use A325 Bolts or equivalent.
 - 2 1/4 inch - 12 ga. PSST to extend entire length inside of the 2 1/2 inch - 12 ga. x 4 inch PSST Stub.
 - Do not use bolt to secure 2 1/4 inch PSST inside of the 2 1/2 inch - 12 ga. x 4 inch PSST Stub.
 - Weld steel according to American Welding Society (AWS) D.1.1.

PERFORATED STEEL SQUARE TUBE (PSST) DETAIL

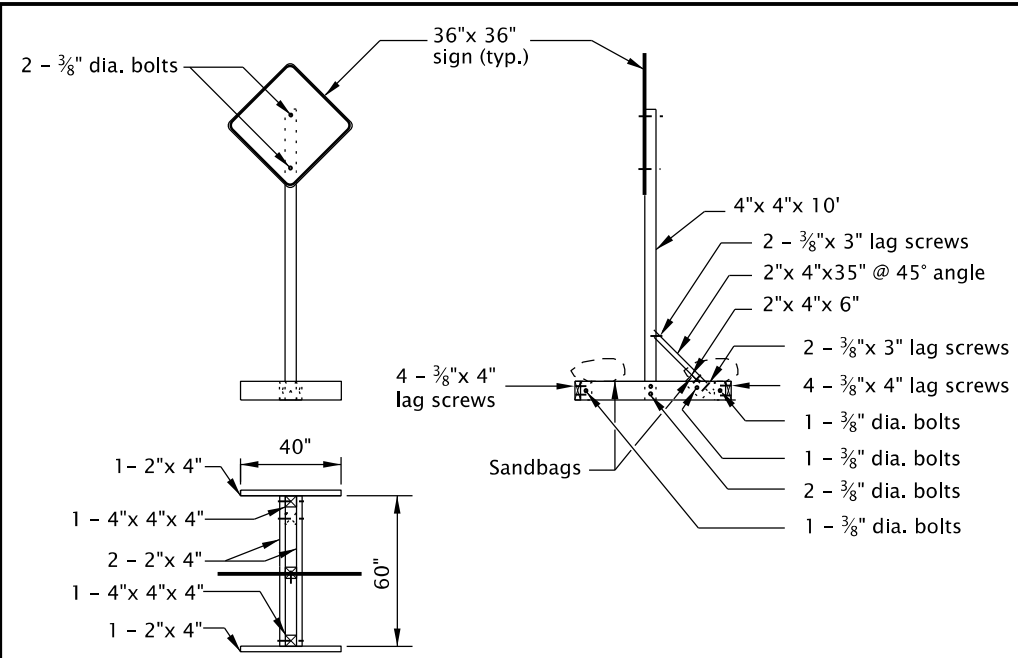

- NOTES:
- Use Single Post TSS for a total sign area of 12 sq. ft. or less.
 - Use Single Post TSS for mounting "Business Access" (CG20-11) signs. Do not mount signs on Type II or III Barricades.

SINGLE POST DETAIL

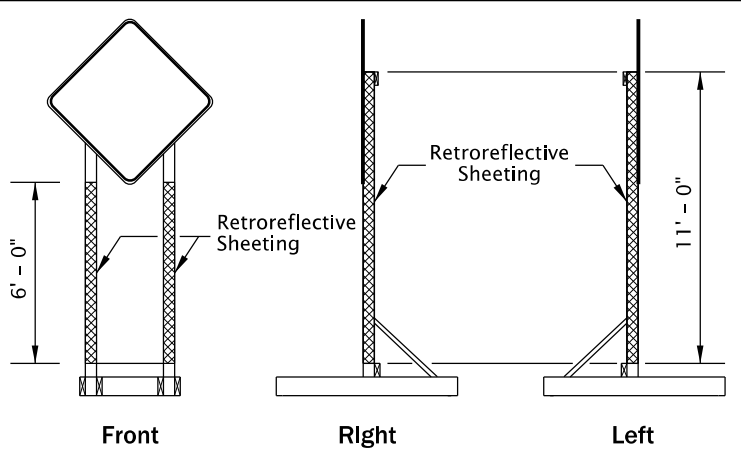

Double Post

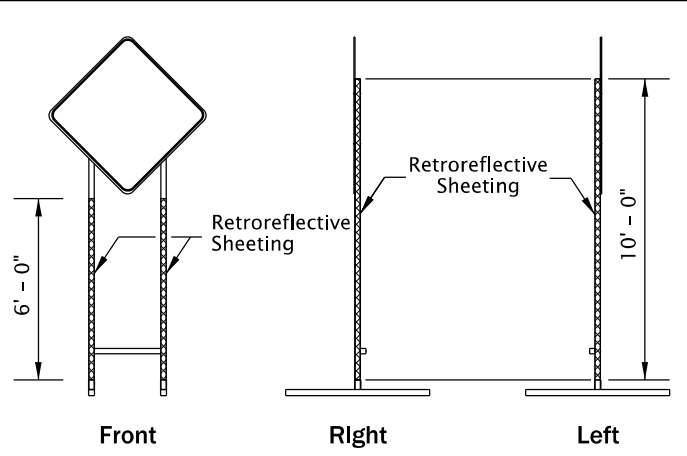

Perforated Steel Square Tube (PSST)

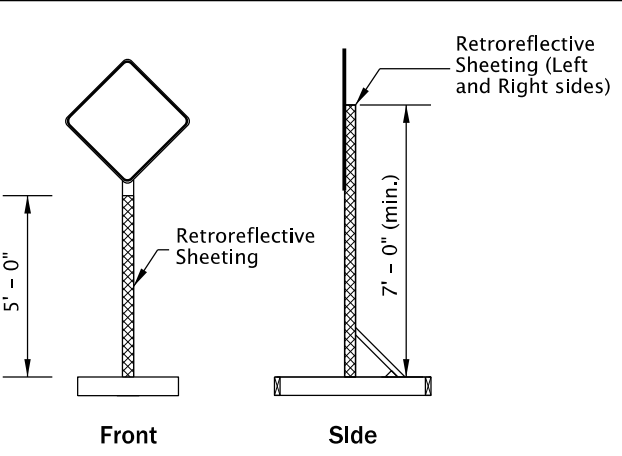

Single Post

Retroreflective Sheeting (Left and Right sides)

- TEMPORARY SIGN SUPPORT GENERAL NOTES:
- Do not tip over TSS at any time.
 - Do not locate TSS's in locations that block pedestrian or bicycle traffic.
 - For wooden TSS's, use either Douglas Fir or Hem Fir, which is surfaced four sides (S4S) and free of heart center (FOHC).
 - See "Temporary Sign Placement" detail on TM822 for sign installation heights.
 - Do not place or stack ballast more than 24" above the ground.
 - When not in use, locate TSS as far from Public Traffic as practicable and turn away from traffic, or cover the sign. Do not cover reflective sheeting on the TSS posts.
 - Place a minimum of 50 lbs of sandbags on each of the four TSS supports legs. (25 lb. max per bag) (min. 100 lbs per side of each TSS).
 - See Dwg. No. TM204 for flag board mounting detail.

- NOTES:
- Apply fluorescent orange, ANSI Type VIII or IX retroreflective sheeting to TSS posts, as shown, for all temporary signs, except "STOP" and "DO NOT ENTER". For "STOP" and "DO NOT ENTER" signs, used red ANSI Type III or IV retroreflective sheeting on the TSS posts.
 - Apply sign post retroreflectivity to each TSS post facing front; and to the left and right sides of the TSS, as shown. Use 3" wide sheeting for wood post TSS's. Use 2" wide sheeting for PSST TSS's.
 - Sheeting may be applied directly to post material; or applied to a rigid, lightweight substrate, then securely attached to the posts.

SIGN POST REFLECTIVE SHEETING PLACEMENT

The selection and use of this Standard Drawing, while designed in accordance with generally accepted engineering principles and practices, is the sole responsibility of the user and should not be used without first consulting a Registered Professional Engineer.

All materials shall be in accordance with the current Oregon Standard Specifications.

OREGON STANDARD DRAWINGS

TEMPORARY SIGN SUPPORTS

2024

DATE	REVISION	DESCRIPTION

CALC. BOOK NO. - - -	N/A - - -	SDR DATE - 14-JUL-2023 -	TM821
----------------------	-----------	--------------------------	--------------

Effective Date: December 1, 2023 – May 31, 2024

NOTES:

- Do not block bicycle lanes, sidewalks, or TPAR's with sign supports. Maintain minimum widths for these facilities according to TCP Design Manual, MUTCD, ADA, or as directed.
- To be accompanied by Dwg. Nos. TM670, TM671, TM687, TM688 & TM689.

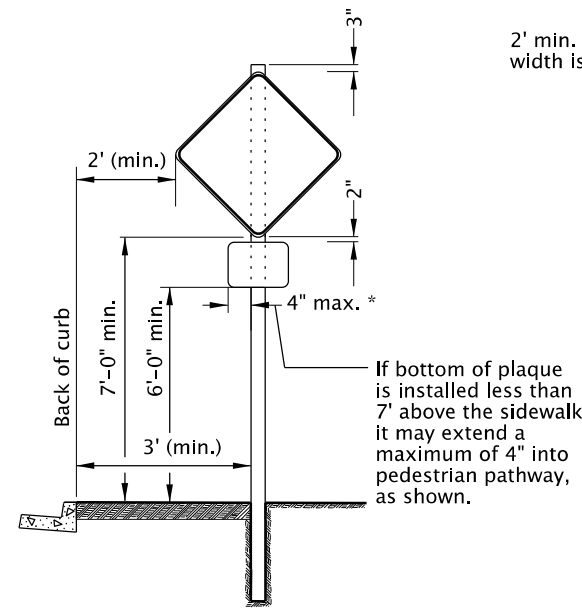

Urban Areas With Curb/Sidewalk

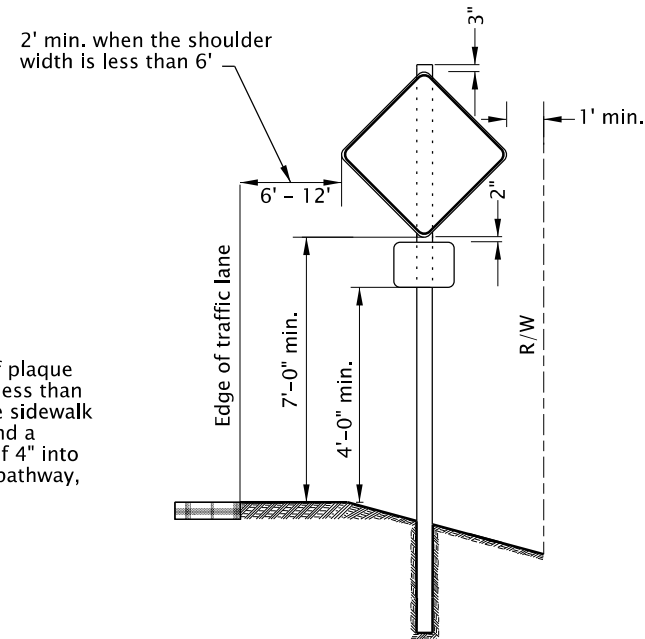

Rural Areas

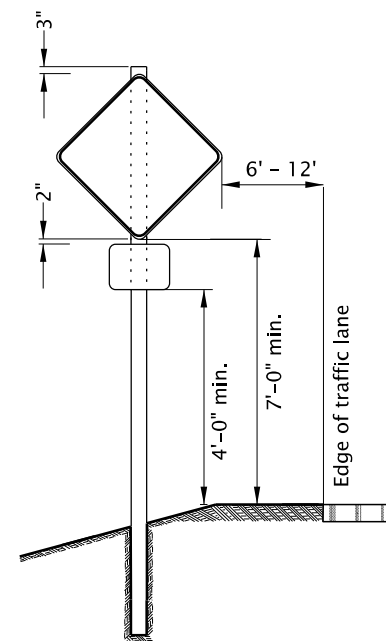

Divided Highway/Freeway Medians
No Curb/Sidewalk

Where temporary signs are located adjacent to or intrude into a paved shoulder or other surface used by bicycle traffic, install secondary sign (plaque) so bottom of sign is a minimum of 7'-0" above pavement surface, as shown.

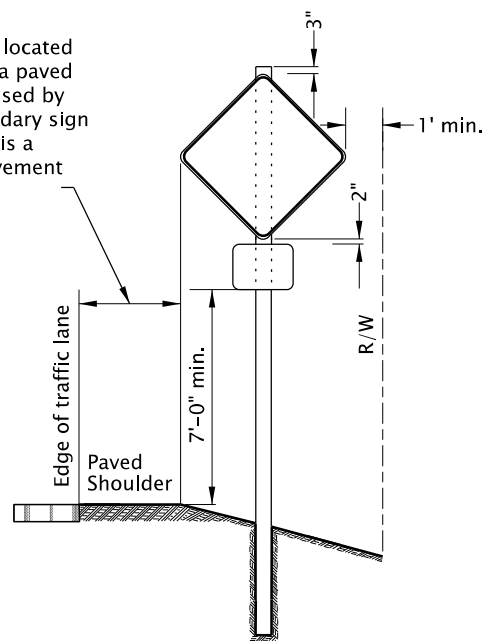

Rural or Urban Areas - Curb or No Curb
Bicycles On Shoulder

TEMPORARY SIGN PLACEMENT

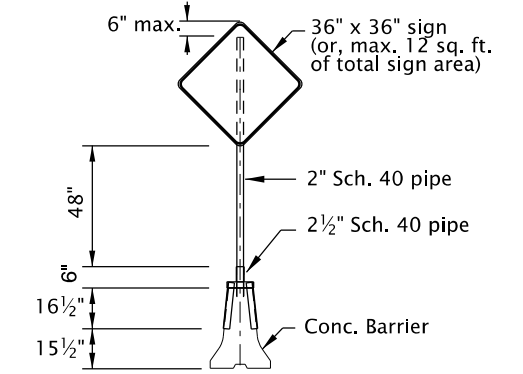
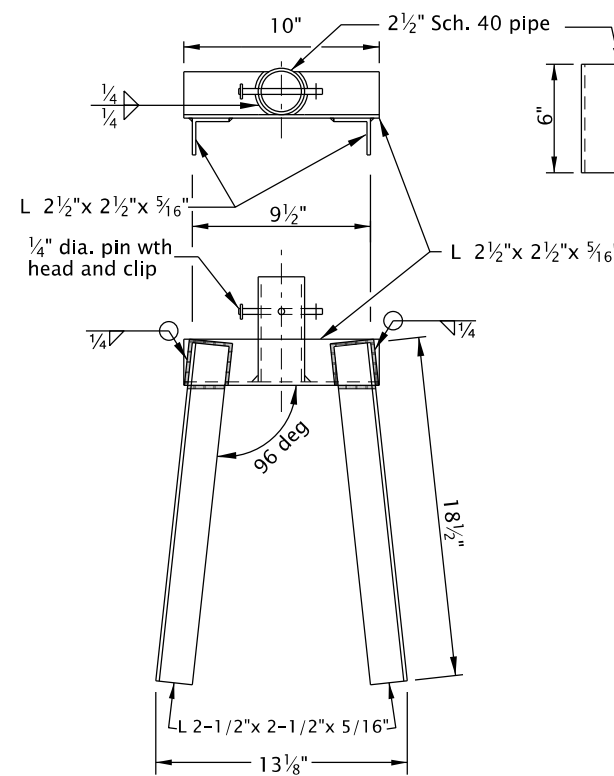

NOTES:

- Drill additional holes so sign can be rotated 90 degrees and pinned when not in use.
- All structural steel shall conform to ASTM A36.
- Support fits both 32" and 42" tall "F" barrier.
- Use for supporting a maximum 12 sq. ft. of total sign area.
- Place support at connection between two concrete barrier sections.
- Weld steel according to American Welding Society (AWS) D.1.1.
- Do not use clipped signs.
- Follow manufacturer recommendation when installing signs on barrier other than concrete.

CONCRETE BARRIER SIGN SUPPORT

The selection and use of this Standard Drawing, while designed in accordance with generally accepted engineering principles and practices, is the sole responsibility of the user and should not be used without first consulting a Registered Professional Engineer.

All materials shall be in accordance with the current Oregon Standard Specifications.

OREGON STANDARD DRAWINGS

TEMPORARY SIGN SUPPORTS

2024

DATE	REVISION	DESCRIPTION

CALC. BOOK NO. ---	N/A ---	SDR DATE 01-JUL-2020	TM822
--------------------	---------	----------------------	-------

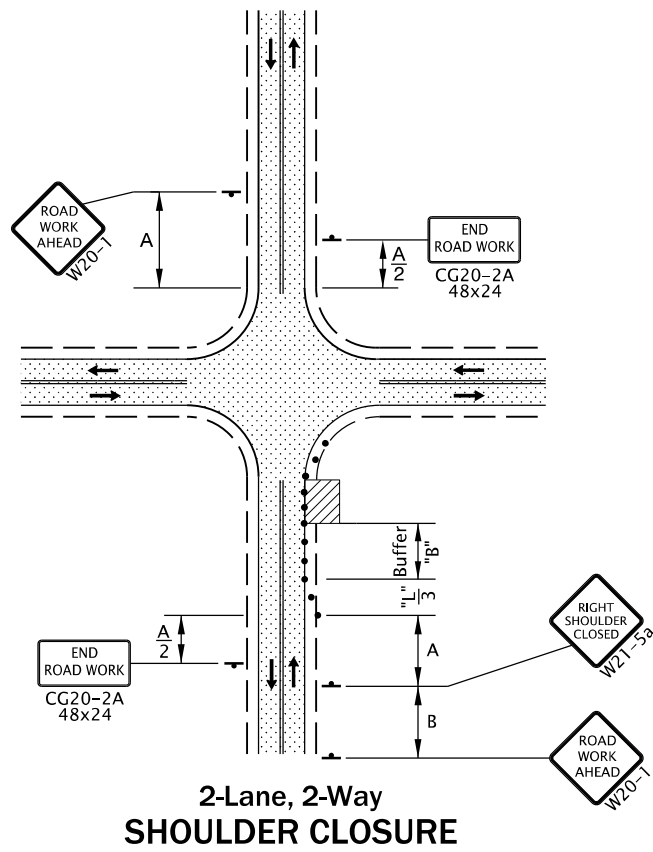

**2-Lane, 2-Way
SHOULDER CLOSURE**

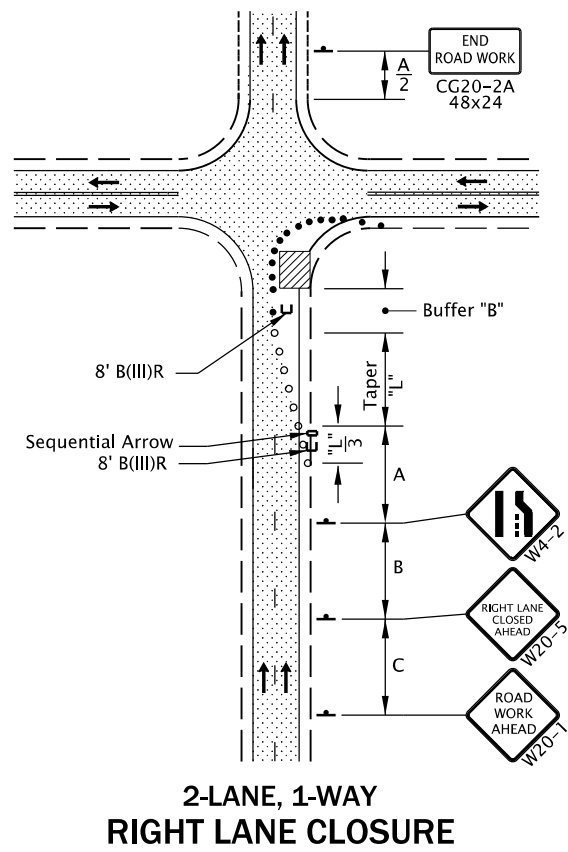

**2-LANE, 1-WAY
RIGHT LANE CLOSURE**

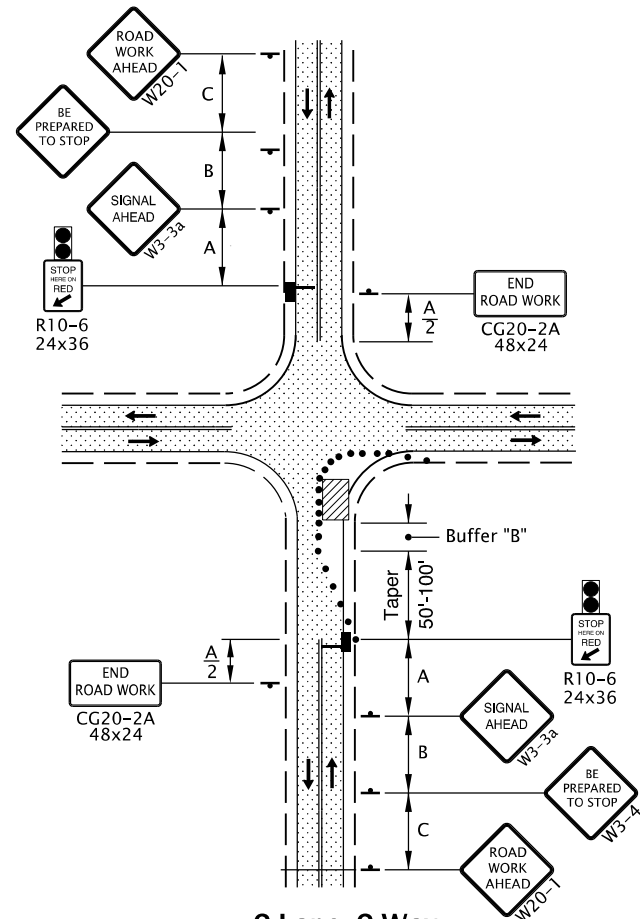

**2-Lane, 2-Way
ONE LANE CLOSURE**

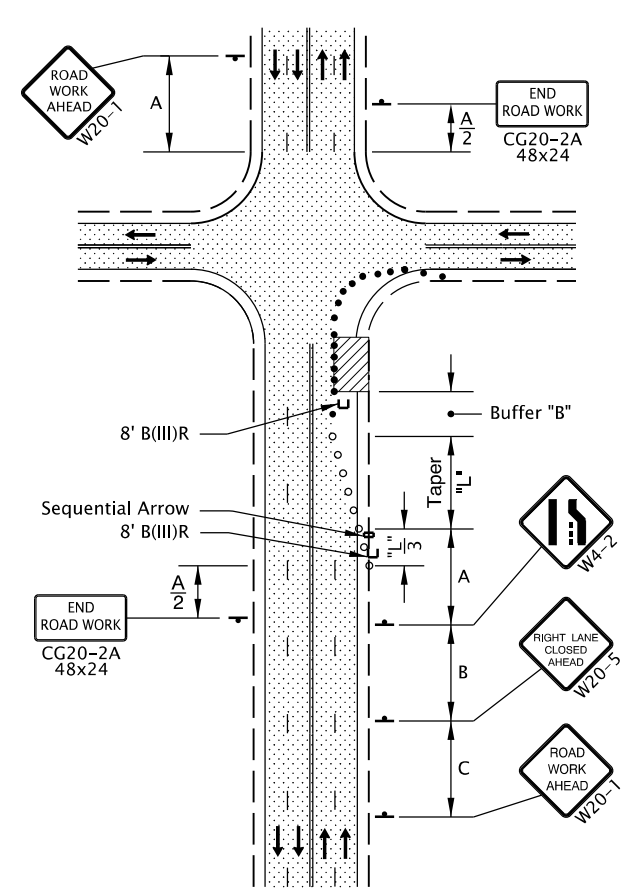

**4-Lane, 2-Way
RIGHT LANE CLOSURE, NEAR SIDE**

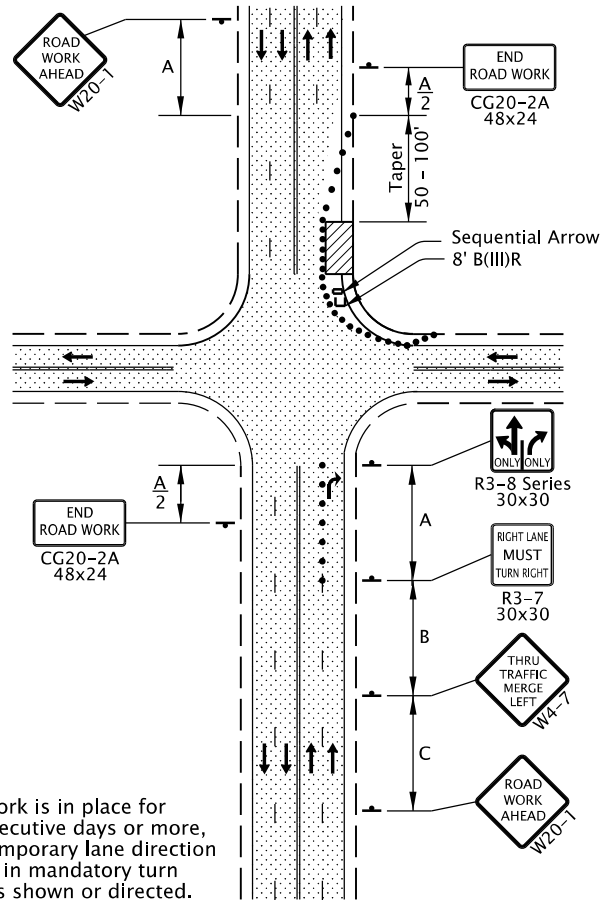

**4-Lane, 2-Way
RIGHT LANE CLOSURE, FAR SIDE**

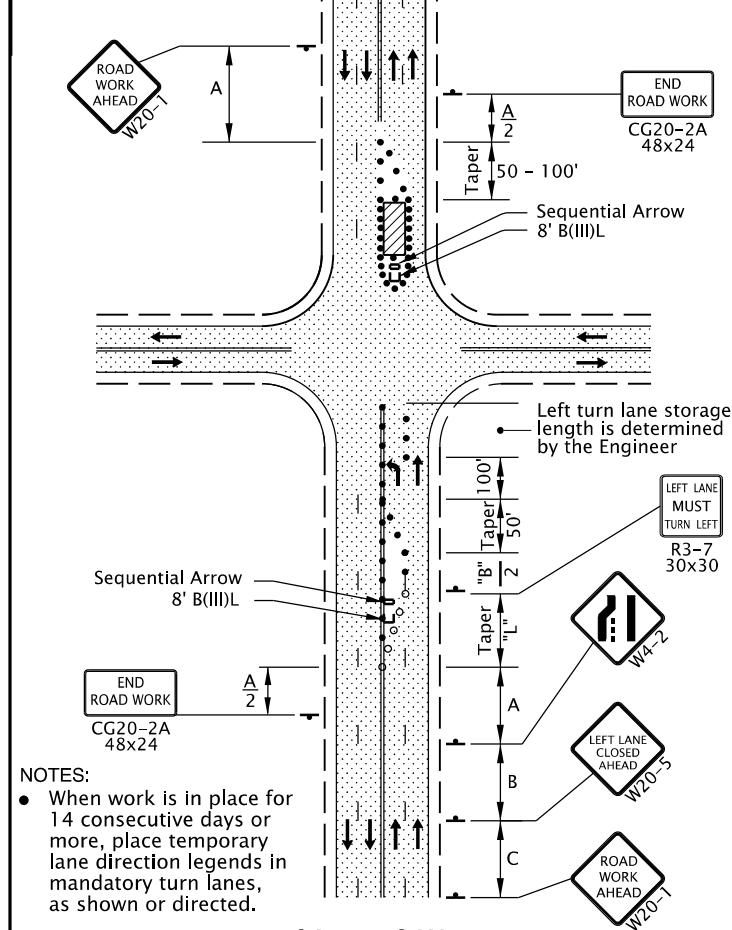

**4-Lane, 2-Way
LEFT LANE CLOSURE, FAR SIDE**

NOTES:
 • When work is in place for 14 consecutive days or more, place temporary lane direction legends in mandatory turn lanes, as shown or directed.

NOTES:
 • When work is in place for 14 consecutive days or more, place temporary lane direction legends in mandatory turn lanes, as shown or directed.

GENERAL NOTES FOR ALL DETAILS:

- Additional Traffic Control Measures (TCM) may be required for all legs of the intersection.
- The "SIGNAL AHEAD" (W3-3a) sign may be substituted with the signal ahead symbol (W3-3) sign.
- To determine Taper Length ("L") and Buffer Length ("B"), use the "MINIMUM LENGTHS TABLE" on Dwg. TM800.
- For left lane or shoulder work, place TCD to close left lane or shoulder. Use "LEFT LANE CLOSED AHEAD" (W20-5) sign, "LEFT LANE ENDS" (W4-2L) symbol sign, or "LEFT SHOULDER CLOSED" (W21-5a) sign, where applicable.
- To determine sign spacing A, B, and C, use "TRAFFIC CONTROL DEVICES (TCD) SPACING TABLE" on Dwg. TM800.
- When a through road intersects within the work zone, place a "ROAD WORK AHEAD" (W20-1) sign in advance of the intersection at sign spacing A.
- Tubular markers may be used in lane closure tapers where posted speed is 40 mph or less.
- Where shoulder width is limited, Sequential Arrow may be placed within the lane closure taper.
- Place channelizing devices around intersection radii, business accesses and driveways at 10' spacing.
- Install a "BICYCLES ON ROADWAY" (CW11-1) sign in advance of the closure when a bike lane is closed, or when the shoulder is closed and bikes are expected.
- To be accompanied by Dwg. Nos. TM820, TM82, TM840 & TM854.

- Automated Flagging Assistance Device (AFAD)
- 28" Tubular Markers See TCD Spacing Table on TM800 for max. spacing.
- ○ ○ ○ ○ Temp. Plastic Drums See TCD Spacing Table on TM800 for max. spacing.
- ▨ UNDER TRAFFIC
- ▩ UNDER CONSTRUCTION

The selection and use of this Standard Drawing, while designed in accordance with generally accepted engineering principles and practices, is the sole responsibility of the user and should not be used without first consulting a Registered Professional Engineer.

All materials shall be in accordance with the current Oregon Standard Specifications.	
OREGON STANDARD DRAWINGS	
INTERSECTION WORK ZONE DETAILS	
2024	
DATE	REVISION DESCRIPTION
CALC. BOOK NO. - - - -	SDR DATE - 01-JUL-2022 -
N/A	TM841

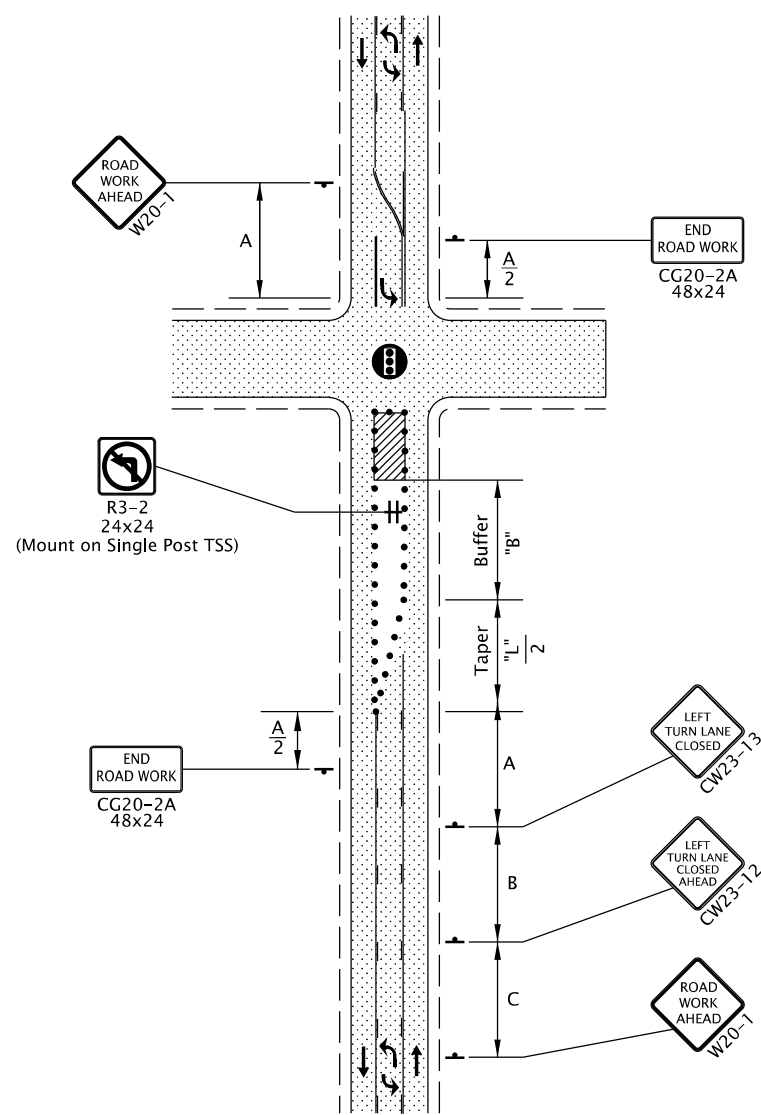

**2-Lane, 2-Way Roadway With Left Turn Median
LEFT TURN MEDIAN CLOSURE**

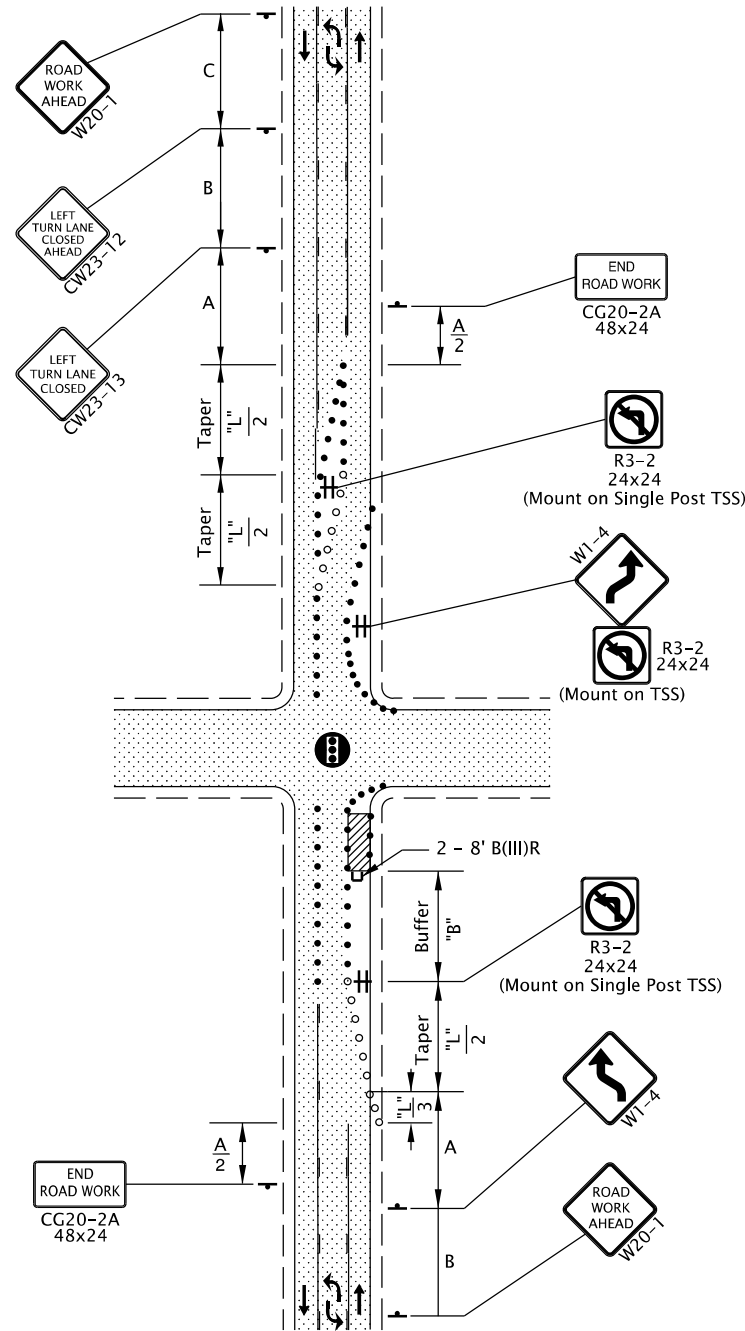

**2-Lane, 2-Way Roadway With Left Turn Median
RIGHT LANE CLOSURE, NEAR SIDE**

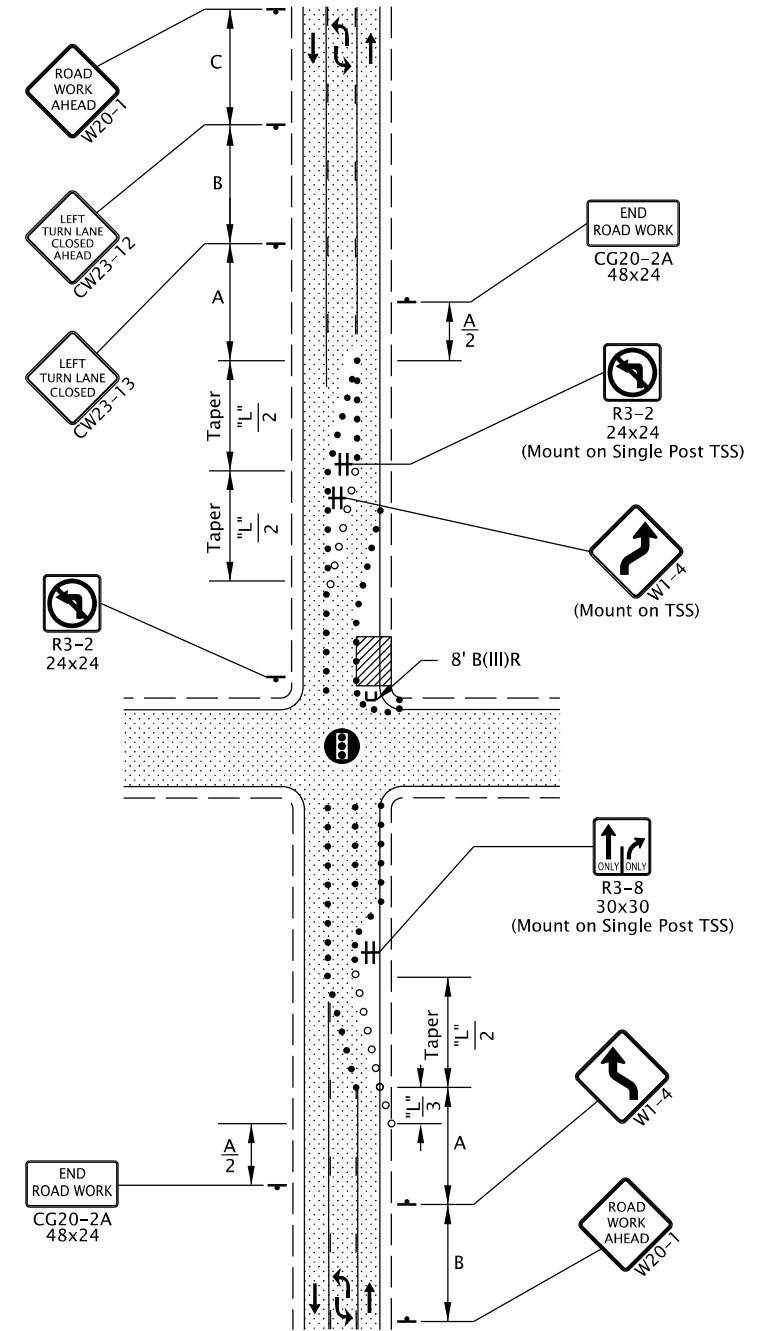

**2-Lane, 2-Way Roadway With Left Turn Median
RIGHT LANE CLOSURE, FAR SIDE**

GENERAL NOTES FOR ALL DETAILS:

- Additional Traffic Control Measures (TCM) may be required for all legs of the intersection.
- To determine Taper Length ("L") and Buffer Length ("B") shown on this sheet, use the "MINIMUM LENGTHS TABLE" on Dwg. TM800.
- Taper length of "L" for through lane shifting tapers may be used for higher speed roads.
- Taper length of "L"/2 for center turn lane closure may be used in areas with a high number of accesses within the work zone.
- When a through road intersects within the work zone, place a "ROAD WORK AHEAD" (W20-1) sign in advance of the intersection at sign spacing A.
- To determine sign spacing A, B, and C, use "TRAFFIC CONTROL DEVICES (TCD) SPACING TABLE" on Dwg. TM800.
- Place channelizing devices around intersection radii, business accesses, and driveways at 10' spacing.
- Tubular markers may be used in lane closure tapers where the posted speed is 40 mph or less.
- Install a "BICYCLES ON ROADWAY" (CW11-1) sign in advance of the closure when a bike lane is closed, or when the shoulder is closed and bikes are expected.
- Signal timing adjustments determined by Engineer.
- To be accompanied by Dwg. Nos. TM820 & TM821.

- Signal
- 28" Tubular Markers
See TCD Spacing Table on TM800 for max. spacing
- Temp. Plastic Drums
See TCD Spacing Table on TM800 for max. spacing
- UNDER TRAFFIC
- UNDER CONSTRUCTION

The selection and use of this Standard Drawing, while designed in accordance with generally accepted engineering principles and practices, is the sole responsibility of the user and should not be used without first consulting a Registered Professional Engineer.

All materials shall be in accordance with the current Oregon Standard Specifications.	
OREGON STANDARD DRAWINGS	
SIGNALIZED INTERSECTION DETAILS	
2024	
DATE	REVISION DESCRIPTION
CALC. BOOK NO. --- N/A ---	SDR DATE-- 01-JUL-2020 -- TM842

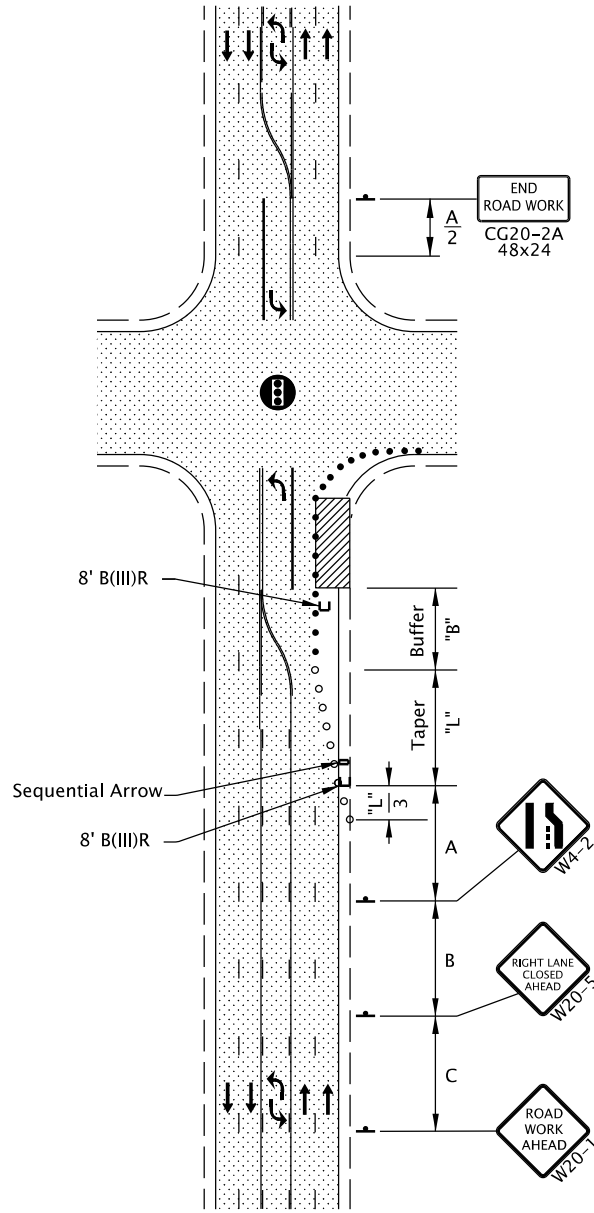

4-Lane, 2-Way Roadway With Left Turn Median
RIGHT LANE CLOSURE

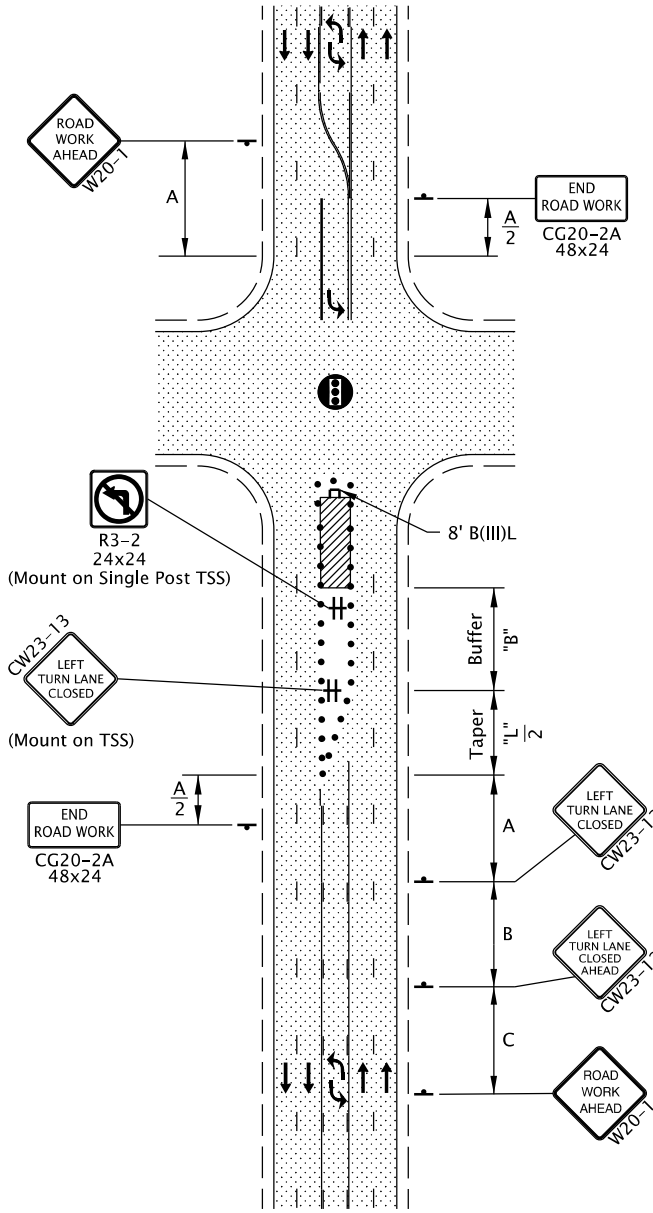

4-Lane, 2-Way Roadway With Left Turn Median
LEFT TURN MEDIAN CLOSURE

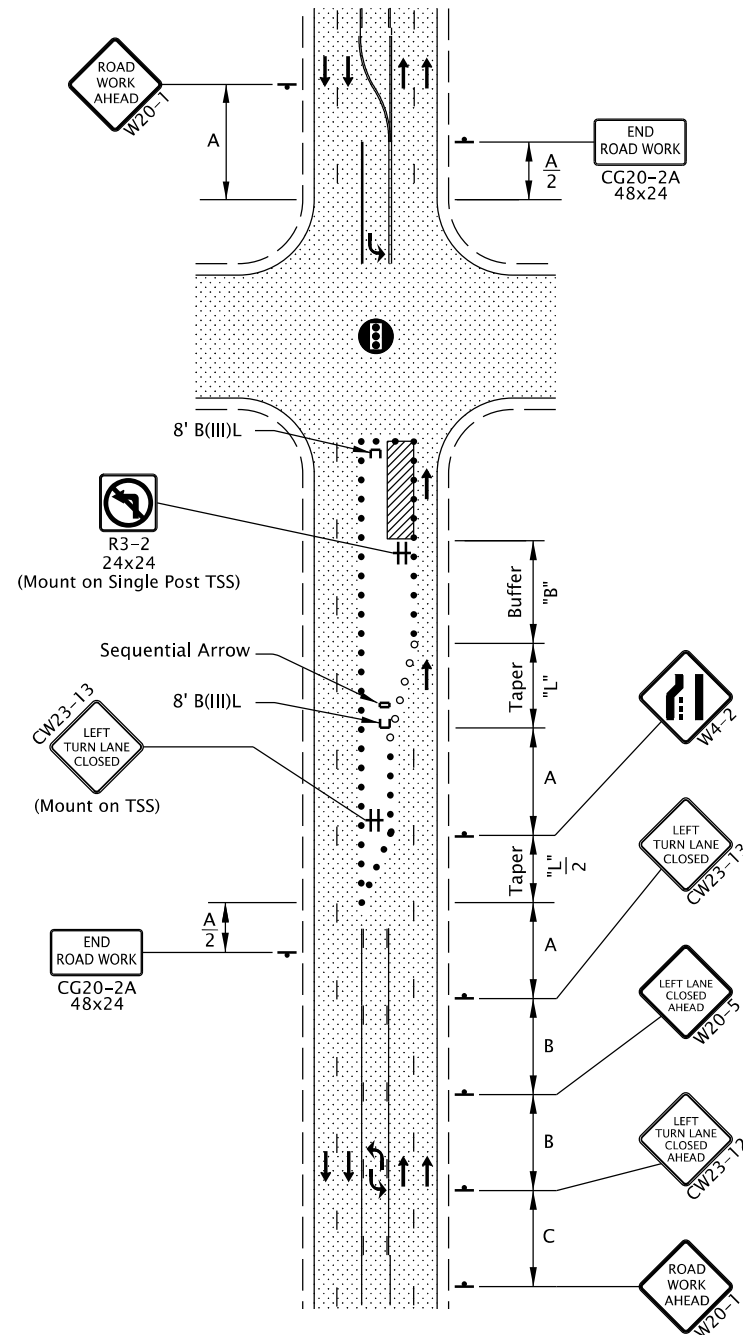

4-Lane, 2-Way Roadway With Left Turn Median
LEFT TURN MEDIAN AND LEFT LANE CLOSURE

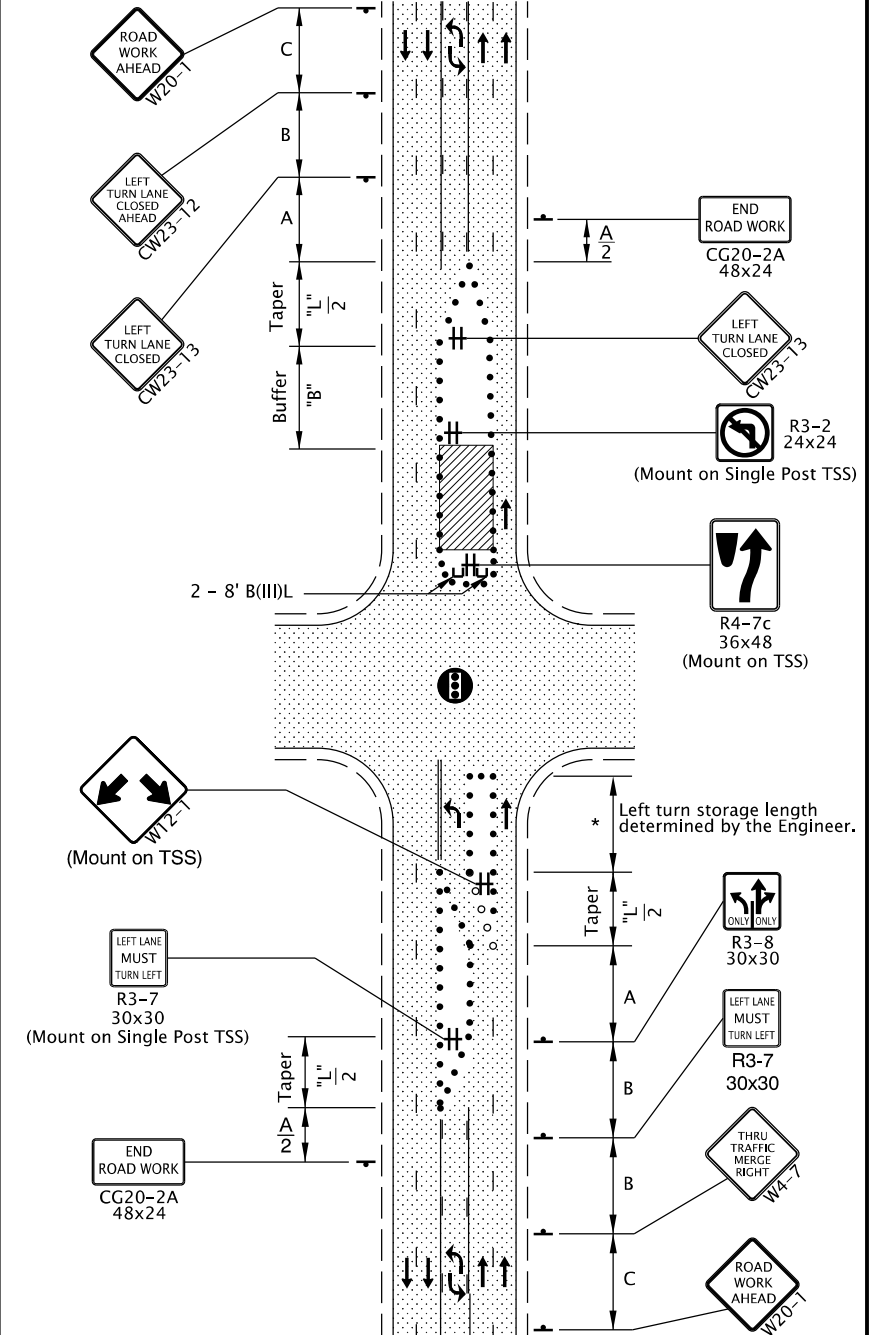

4-Lane, 2-Way Roadway With Left Turn Median
LEFT TURN MEDIAN & LEFT LANE CLOSURE, FAR SIDE

GENERAL NOTES FOR ALL DETAILS:

- Additional Traffic Control Measures (TCM) may be required for all legs of the intersection.
- To determine Taper Length ("L") and Buffer Length ("B") shown on this sheet, use the "MINIMUM LENGTHS TABLE" on Dwg. TM800.
- When a through road intersects within the work zone, place a "ROAD WORK AHEAD" (W20-1) sign in advance of the intersection at sign spacing A.
- To determine sign spacing A, B, and C, use "TRAFFIC CONTROL DEVICES (TCD) SPACING TABLE" on Dwg. TM800.
- Tubular markers may be used in lane closure tapers where the posted speed is 40 mph or less.
- Taper Length of "L" for the through-lane shifting tapers may be used for higher speed roads.
- Taper Length of "L"/2 for center turn lane closure may be used in areas with high number of accesses within the work zone.
- Place channelizing devices around intersection radii, business accesses and driveways at 10' spacing.
- Install a "BICYCLES ON ROADWAY" (CW11-1) sign in advance of the closure when a bike lane is closed, or when the shoulder is closed and bikes are expected.
- Signal timing adjustments determined by the Engineer.
- To be accompanied by Dwg. Nos. TM820 & TM821.

- [Signal symbol] Signal
- [Tubular markers symbol] 28" Tubular Markers See TCD Spacing Table on TM800 for max. spacing.
- [Plastic drums symbol] Temp. Plastic Drums See TCD Spacing Table on TM800 for max. spacing.
- [Dotted pattern symbol] UNDER TRAFFIC
- [Hatched pattern symbol] UNDER CONSTRUCTION

The selection and use of this Standard Drawing, while designed in accordance with generally accepted engineering principles and practices, is the sole responsibility of the user and should not be used without first consulting a Registered Professional Engineer.

All materials shall be in accordance with the current Oregon Standard Specifications.

OREGON STANDARD DRAWINGS

MULTI-LANE SIGNALIZED INTERSECTION DETAILS

2024

DATE	REVISION	DESCRIPTION

CALC. BOOK NO. - - -	N/A - - -	SDR DATE - 01-JUL-2020 -	TM843
----------------------	-----------	--------------------------	--------------

14-JUL-2023

TM844.dgn

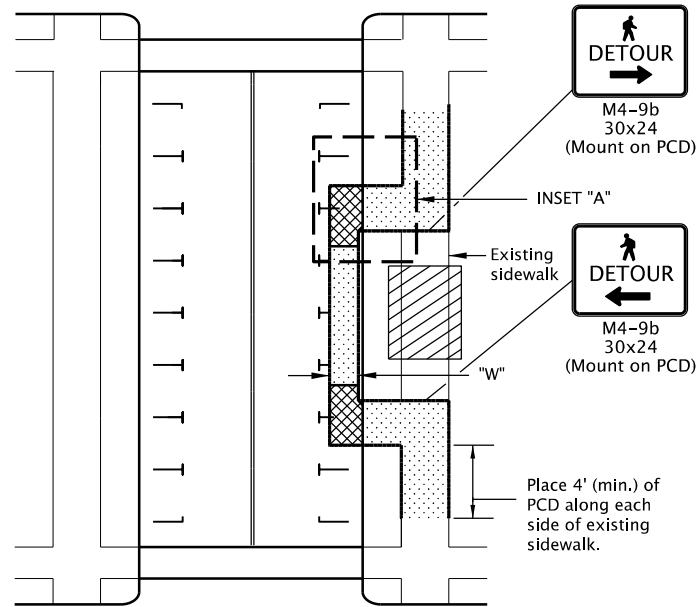

Within Roadway SIDEWALK DIVERSION

- NOTES:
- Place or construct temp. sidewalk ramp, as needed.
 - For roadways with a pre-construction posted speed of 40 mph or less.
 - See inset "A" for Temp. Sidewalk Ramp details.
 - "W" = 60", or, where 60" width cannot be maintained through the entire route, provide 48" min. width with 60" x 60" passing spaces every 200 ft.
 - Use temporary ADA compliant surfaces to cross planter strips or other non-traversable surfaces.

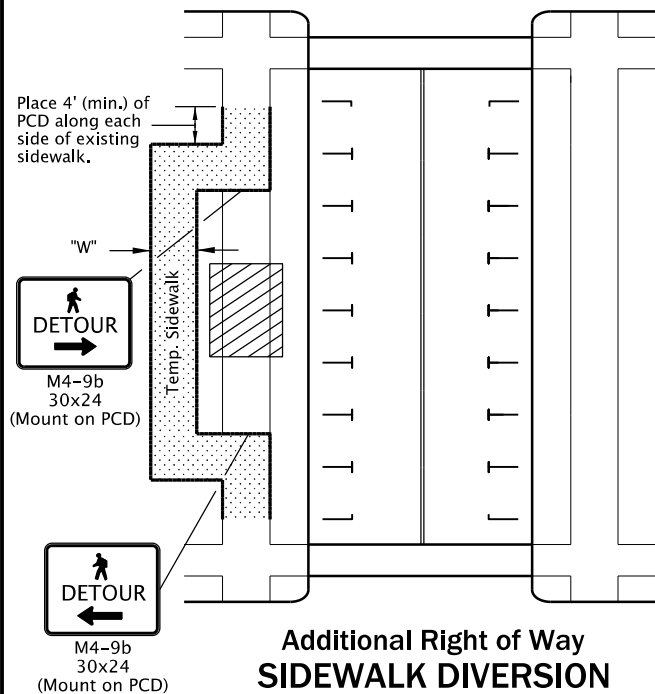
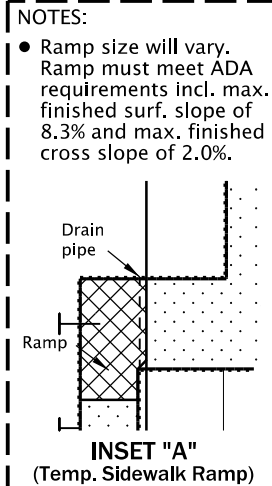

Additional Right of Way SIDEWALK DIVERSION

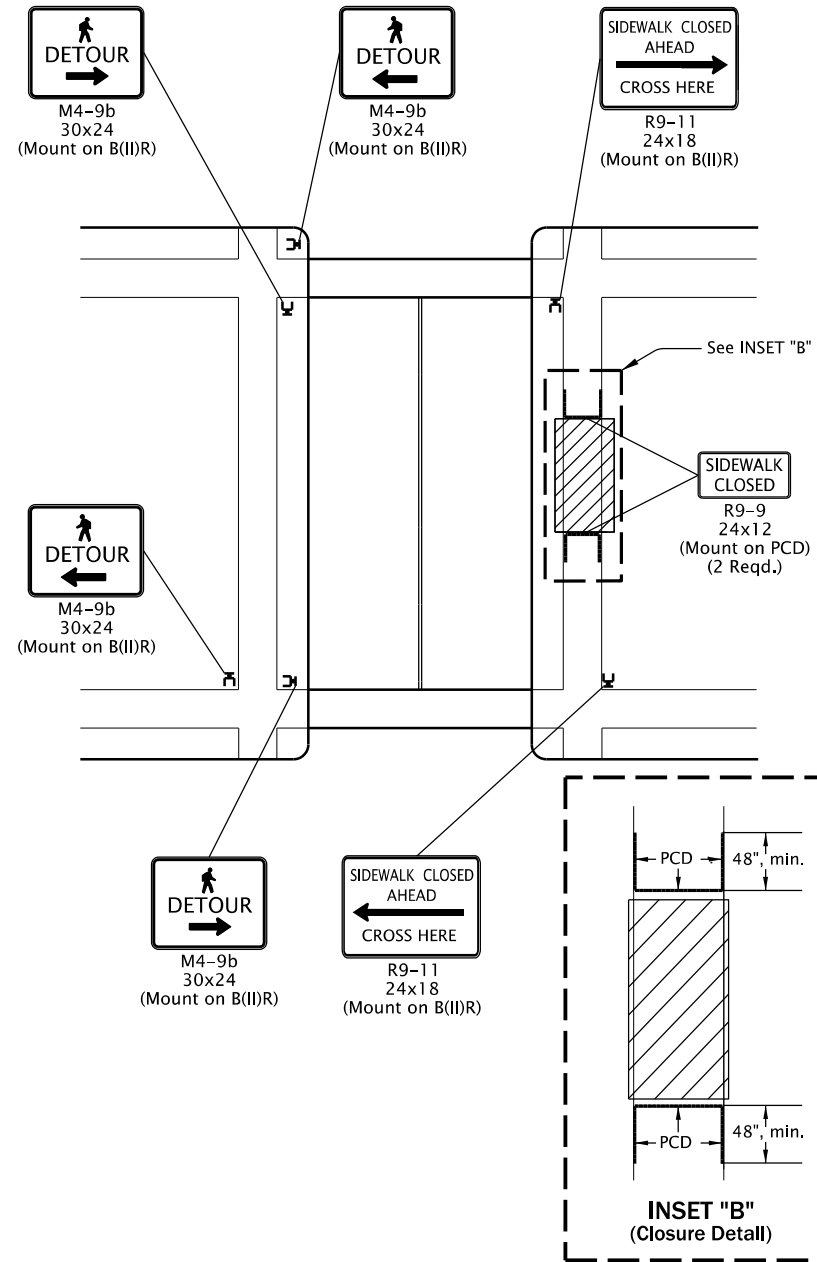

SIDEWALK CLOSURE, MIDBLOCK

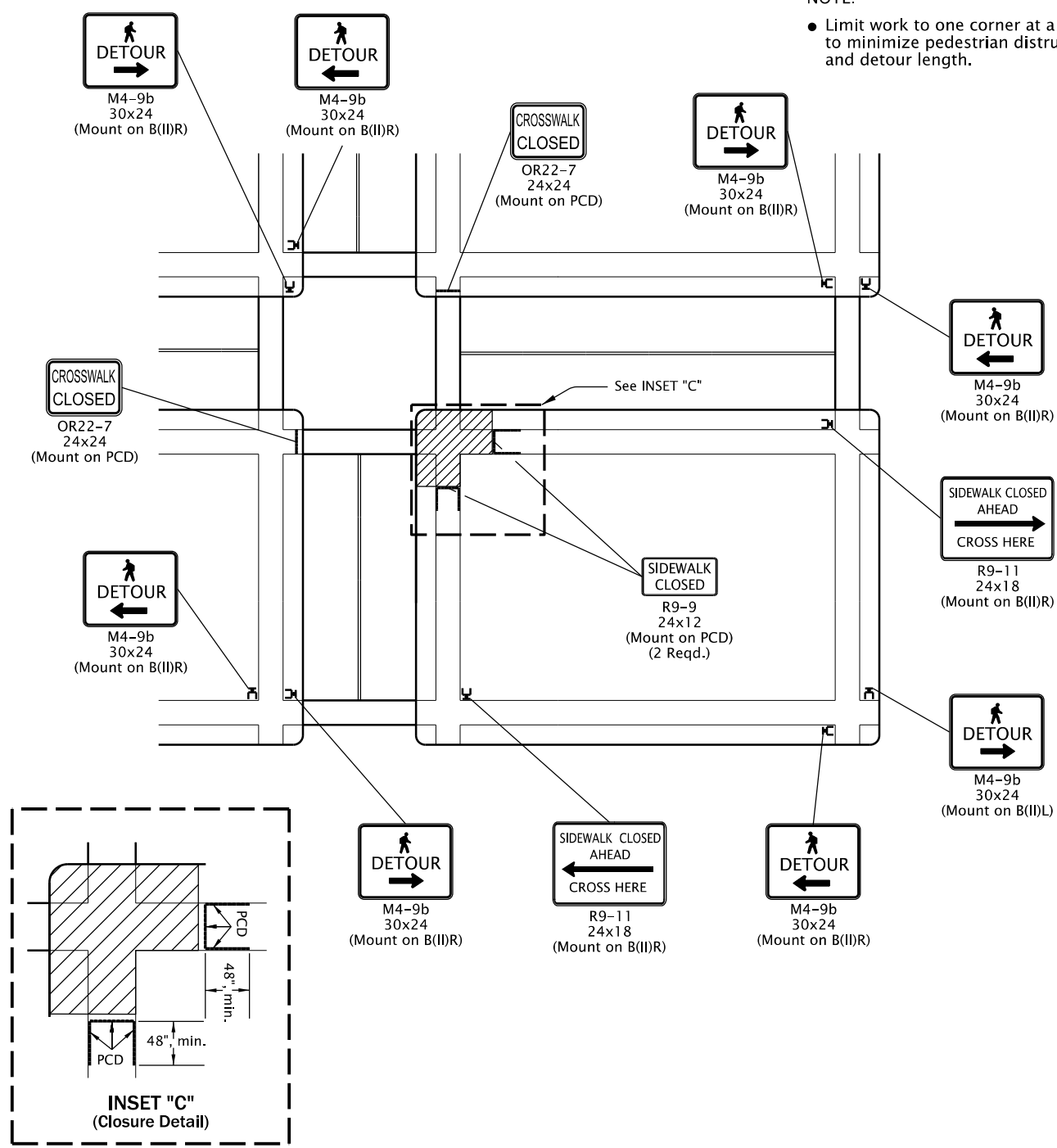
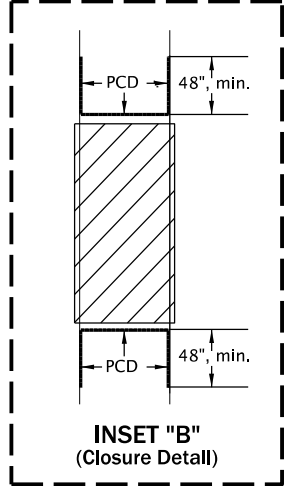

SIDEWALK CLOSURE, CORNER

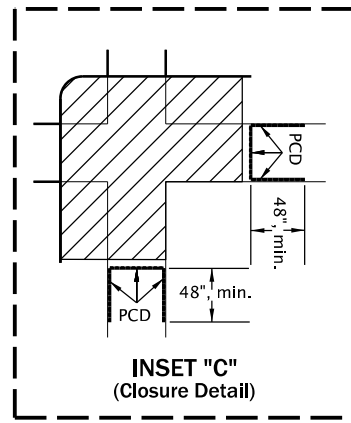

GENERAL NOTES FOR ALL DETAILS:

- When closing or relocating crosswalks or other pedestrian facilities provide ADA compliant facilities. Include accessibility features consistent with existing pedestrian facilities by providing adequate slope transitions and surfacing.
- Provide non-slip, 60 inch minimum wide surface through entire pedestrian route. If not possible, provide 48" min. width with 60" x 60" passing spaces every 200 feet along the route.
- Only TCD for pedestrians are shown. Other devices may be necessary to control vehicular traffic.
- Stage work, as necessary, to provide a temporary pedestrian access route at all times. For roadways with no available detours, maintain one open sidewalk at all times.
- Minimize pedestrian out-of-direction travel.
- To be accompanied by Dwg. Nos. TM820 & TM821.

- UNDER PEDESTRIAN TRAFFIC
- UNDER CONSTRUCTION
- PEDESTRIAN CHANNELIZING DEVICE (PCD)

The selection and use of this Standard Drawing, while designed in accordance with generally accepted engineering principles and practices, is the sole responsibility of the user and should not be used without first consulting a Registered Professional Engineer.

NOTE:
• Limit work to one corner at a time to minimize pedestrian disruption and detour length.

All materials shall be in accordance with the current Oregon Standard Specifications.

OREGON STANDARD DRAWINGS TEMPORARY PEDESTRIAN ACCESSIBLE ROUTES

2024

DATE	REVISION DESCRIPTION
01-2022	Revised notes for temporary sidewalk ramp.
07-2023	OR22-8 signs were replaced with OR22-7 signs.

CALC. BOOK NO.	N/A	SDR DATE	14-JUL-2023	TM844
----------------	-----	----------	-------------	-------

Effective Date: December 1, 2023 – May 31, 2024

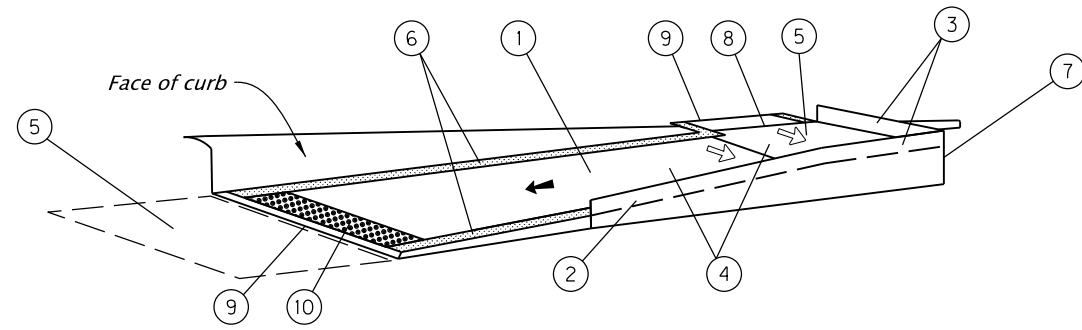

TEMPORARY CURB RAMP, PARALLEL TO CURB

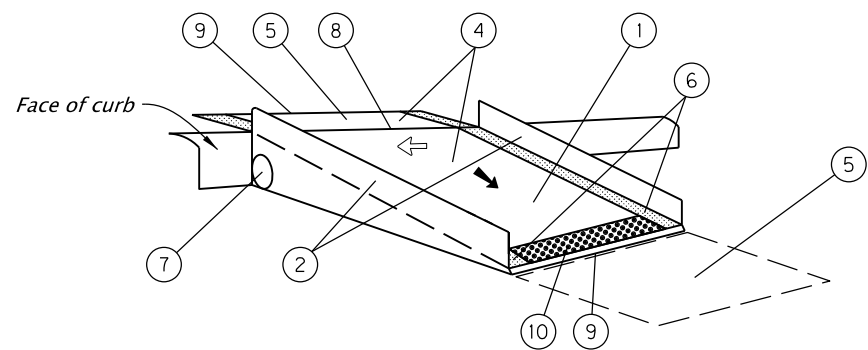

WITH PROTECTIVE EDGE

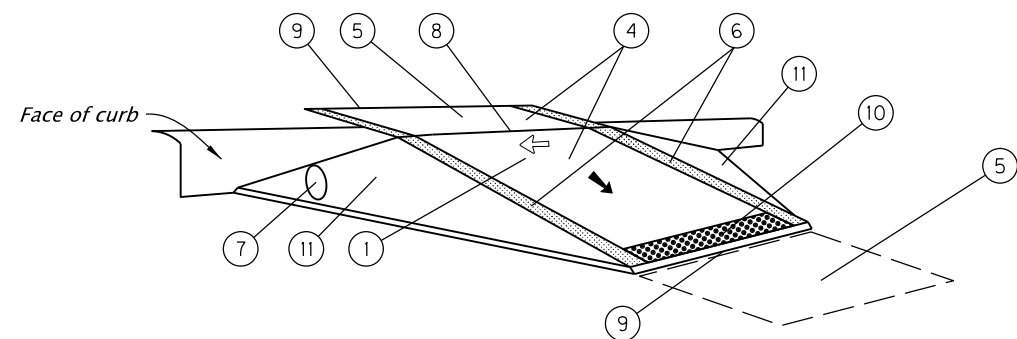

WITH SIDE FLARES

TEMPORARY CURB RAMP, PERPENDICULAR TO CURB

GENERAL CONSTRUCTION NOTES:

- ① Clear width shall be greater than or equal to 48 inches. The curb ramp surface shall be firm, stable and slip-resistant. The ramp surface shall have a 8.3% max. finished surface slope.
- ② Detectable edging with a min. 6 inch height shall be placed along the ramp run when there is a vertical drop exceeding 6 inches or is adjacent to a slope exceeding 1:3 (v:h).
- ③ Detectable edging with 6 inch min. height and contrasting color shall be placed on all turning spaces where the walkway changes direction.
- ④ Curb ramps and turning spaces shall have a 2.0% max. finished cross slope.
- ⑤ Clear space of 48 inch x 48 inch or greater shall be provided above and below the curb ramp.
- ⑥ The curb ramp walkway edge shall be marked with a contrasting color, 4 inch wide stripe. The marking is optional where contrasting detectable edging is used.
- ⑦ Provide an approved means to prevent water from accumulating at the bottom of the ramp, or overflowing onto the ramp surface.
- ⑧ Lateral joints or gaps between surfaces shall be less than 0.5 inch wide. Surface slopes that meet at grade break shall be flush. See edge treatment detail.
- ⑨ Changes between surface heights shall not exceed 0.5 inch. Lateral edges should be vertical up to 0.25 inch high, and beveled at 1:2 (v:h) between 0.25 inch and 0.5 inch height. See edge treatment detail.
- ⑩ Install a min. 2 ft wide detectable warning surface at pedestrian street crossings. Omit detectable warning surfaces at end of sidewalk transitions that are not at a crosswalk.
- ⑪ Side flares where provided shall have 10% max. slope.
- ⑫ The curb ramp surface shall be capable of supporting a min. surface load of approximately 800 pounds.
- ⑬ The curb ramp shall be either self-balasting or include an anchoring system capable of keeping the platform stationary under pedestrians traffic including motorized wheelchairs.
- ⑭ The curb ramp platform shall be free of sharp or rough edges or abrasive elements that may harm pedestrians.

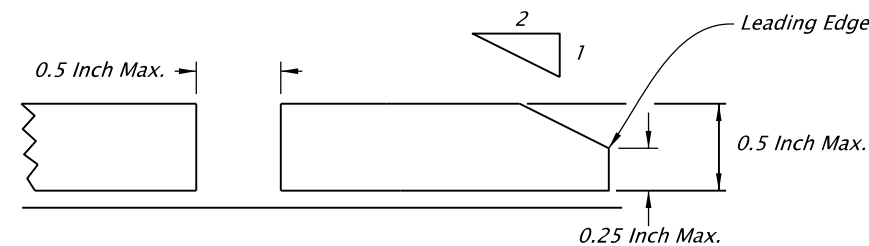
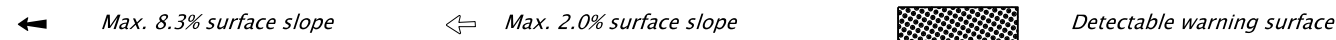

EDGE TREATMENT DETAIL

The selection and use of this Standard Drawing, while designed in accordance with generally accepted engineering principles and practices, is the sole responsibility of the user and should not be used without first consulting a Registered Professional Engineer.

All materials shall be in accordance with the current Oregon Standard Specifications.

OREGON STANDARD DRAWINGS

TEMPORARY SIDEWALK RAMPS

2024

DATE	REVISION	DESCRIPTION
07-2023	NEW DRAWING CREATED	
CALC. BOOK NO.	N/A	SDR DATE

14-JUL-2023

TM845